

Get started in QualiWare

Introduction to QualiWare – basic navigation and modeling via the Web

qualiware

Agenda

- Workspace and navigation
 - Menu
 - Desktops
 - QualiAI
 - QualiChat
 - Toolbar
 - QualiHelp
- How to draw diagrams
- How to describe diagrams and symbols
- How to link across diagrams
- External documents
- How to describe the organization
- Linking content together
- Spreadsheet
- Analyzing and exploring the repository

The screenshot displays the Qualiware user desktop interface. The top navigation bar includes 'qualiware', 'User desktop 1', 'USER DESKTOP', and 'Layout: My desktop'. The interface is divided into several panels:

- Left Sidebar:** A vertical navigation menu with icons for Desktops, Strategy, Process, Application, Information, Organization, Technology, Compliance, Sustainability, and Risk.
- My personal actions:** A list of tasks with checkboxes, including 'My To-Do List', 'My Responsibilities', 'My Subscriptions', 'My Feedback', 'Compliance and risk', 'Provide feedback', 'Register ChangeRequest', 'Register Idea', and 'Register Problem'.
- Quick search:** A search box with fields for Name, Template, Responsible, and Owner.
- Top process:** A flowchart showing business processes: 'Purchase product', 'Market product and service', 'Provide product', 'Manage and control business', 'Perform overhaul', 'Manage human resources', 'Handle payment', and 'Manage infrastructure'.
- Top Business Operating Model:** A complex flowchart titled 'Chixi Overview Business Operating Model'.
- My Top 20 hits for the last 30 days:** A horizontal bar chart showing search results for various items like 'Chixi Car Renta...', 'Chixi Processes', 'Manage and cont...', 'Response Busin...', 'Perform Weekly ...', 'Financial State ...', 'Create Solution', 'Design Concept', 'Prepare, instal...', 'Manage human re...', 'test', 'Define ways of ...', 'Develop System', 'Approve ECR', 'Chixi Overview', 'test8', 'Baggage claim', 'test7', and 'Test07'.
- Manage business processes:** A panel with options: 'Create Business Process content', 'Edit Business Process content', 'View Business Process content', 'Processes and ownership', and 'Edit process definitions'.
- Business Process Network - Gov...:** A pie chart with a legend: 'Approved' (blue), 'Circulation' (red), 'Development' (green), 'Finished' (yellow), and 'Ready for approval' (purple).
- Work Flow Dia. - Gov. State:** A pie chart with a legend: 'Approved' (blue), 'Development' (red), and 'Finished' (green).

The Qualiware logo is visible in the bottom left corner of the interface.



Workspace and navigation

qualiware

QualiWare Platform

- Left side **Menu** gives you access to a set of standard lists and analyses
- **Desktops** is a "one stop" starting point of a business focus, architectural domain or a governance, risk and compliance focus.
- **QualiAI**, helps you generate and enrich your content
- **QualiChat**, is an AI chatbot where you can ask about the content in your own natural language
- **Toolbar** consist of a set of actions button where you can find your To Do's, subscription and other essential features
- **QualiHelp**, is by your side both when you are exploring the platform or creating models in the web-modeler



















The image shows a screenshot of the QualiWare Platform interface. The interface is divided into several sections:

- Menu:** A vertical sidebar on the left containing icons for Desktops, Strategy, Process, Application, Information, Organization, Technology, Compliance, Sustainability, and Risk.
- Desktops:** A horizontal navigation bar at the top with tabs for USER DESKTOP, COMPLIANCE, APPLICATION MANAGEMENT, PROCESS MANAGEMENT (selected), and RISK MANAGEMENT.
- QualiAI:** A dark blue button with a brain icon, located above the Desktops bar.
- QualiChat:** A blue button with a chat icon, located above the Desktops bar.
- Toolbar:** A green button with a gear icon, located above the Desktops bar.
- QualiHelp:** A dark blue button with a question mark icon, located at the bottom right of the interface.

The main content area displays a dashboard with several widgets:

- Top process:** A flowchart showing steps like 'Manage Financial Resources', 'Manage and Control Business', 'Financial Statement Close Process', 'Purchase product', 'Market product and service', 'Provide product', 'Perform overhaul', 'Manage Human Resources', 'Handle payment', and 'Manage Infrastructure'.
- Getting started:** A list of actions including 'Import', 'Create Business Process content', 'Edit Business Process content', 'View Business Process content', and 'Approach to Business Process Management'.
- Establish an overview of current situation:** A list of categories such as 'Processes and ownership', 'Business logistics and value streams', 'Processes - IGOE', 'Value Chain Models', 'Value Stream Models', 'Business Diagrams', 'Manufacturing Routing Network', and 'Provide feedback'.
- Evaluate business processes:** A list of categories including 'Process risk & compliance', 'Completion and performance', 'Business Process Completion', 'Work Process Completion', 'Processes - Performance', 'Key Performance Indicators', and 'Digital aspects'.
- Design and implement business process:** A list of categories including 'Planning change', 'Models require change', 'Strategic Roadmap planning', 'Initiatives affecting processes', 'Projects affecting processes', and 'Edit process definitions'.
- Process hierarchy:** A tree view showing a process structure for 'Chixi Car Rental Processes' with sub-items like 'Financial Statement Close', 'Handle payment', 'Manage and control the business', 'Manage Human Resources', 'Manage infrastructure', 'Market product and service', 'Perform overhaul', 'Provide Car Rental Service', 'Book car', 'Perform overhaul', 'Perform service', 'Purchase car', 'Chixi Process Overview', and 'Wayfinding'.
- Process News:** A section for 'Local Process News' and 'Something exiting' with dates and authors.
- Business Process Network - Go...:** A pie chart showing status distribution: Approved (red), Development (blue), Finished (green), and Ready for approval (yellow).
- Work Flow Dia. - Gov. State:** A pie chart showing status distribution: Approved (red), Development (blue), Finished (green), and Ready for approval (yellow).
- Bus. Process Dia. - Gov. state:** A pie chart showing status distribution: Approved (red), Development (blue), Finished (green), and Ready for approval (yellow).
- Operating Model:** A complex flowchart titled 'Chixi Overview Business Operating Model'.
- Top Value chain model:** A flowchart showing a value chain with steps like 'Supplier', 'Logistics', 'Order handling', 'Annual handling', 'Lead times', 'Sales Order', 'Production', 'Delivery', 'Customer', 'Service', 'Support', 'Maintenance', 'Warranty', 'Complaints', 'Returns', 'Recalls', 'Incidents', 'Disputes', 'Litigation', 'Claims', 'Settlements', 'Recovery', 'Resolution', 'Feedback', 'Improvement', 'Innovation', 'Sustainability', 'Compliance', 'Risk Management', 'Security', 'Privacy', 'Data Protection', 'GDPR', 'Cybersecurity', 'IT Security', 'Business Continuity', 'Disaster Recovery', 'Business Resilience', 'Resilience', 'Adaptability', 'Agility', 'Flexibility', 'Scalability', 'Efficiency', 'Effectiveness', 'Productivity', 'Performance', 'Quality', 'Customer Satisfaction', 'Employee Satisfaction', 'Stakeholder Satisfaction', 'Sustainability', 'Resilience', 'Adaptability', 'Agility', 'Flexibility', 'Scalability', 'Efficiency', 'Effectiveness', 'Productivity', 'Performance', 'Quality', 'Customer Satisfaction', 'Employee Satisfaction', 'Stakeholder Satisfaction'.

Enterprise Architecture Framework

	Strategy	Process	Application	Information	Organization	Technology
Conceptual	 <p>Strategy</p>	 <p>Business Process Model</p>	 <p>Application Architecture</p>	 <p>Semantic Model</p>	 <p>Stakeholder Model</p>	 <p>Strategic Technology Model</p>
Logical	 <p>Policies</p>	 <p>Business Process Design</p>	 <p>System Design</p>	 <p>Logical Data Model</p>	 <p>Organization Model</p>	 <p>Business Technology</p>
Operational	 <p>Business Rules</p>	 <p>Work Flow</p>	 <p>Component Model</p>	 <p>Physical Data Model</p>	 <p>Human Resource Model</p>	 <p>Physical Technology</p>

QualiWare supports all dimensions of the Enterprise Architecture Framework.

The desktops and menu (cf. next slide) contains relevant subset for each of the columns in the Enterprise Architecture framework

Workspace – Left menu

Left side **menu** gives you access to a set of standard content, lists and analyses

The default menu contains an entry for each column in the Enterprise Architecture framework as well as governance, risk and compliance contents

	Strategy	Process	Application	Information	Organization	Technology
Conceptual	Strategy Model	Business Process Model	Application Architecture	Semantic Model	Stakeholder Model	Strategic Technology Model
Logical	Policies	Business Process Design	System Design	Logical Data Model	Organization Model	Business Technology
Operational	Business Rules	Work Flow	Component Model	Physical Data Model	Human Resource Model	Physical Technology

The menu also contain a full list of all standard desktops (see next slide).

The Menu can be configured and customized

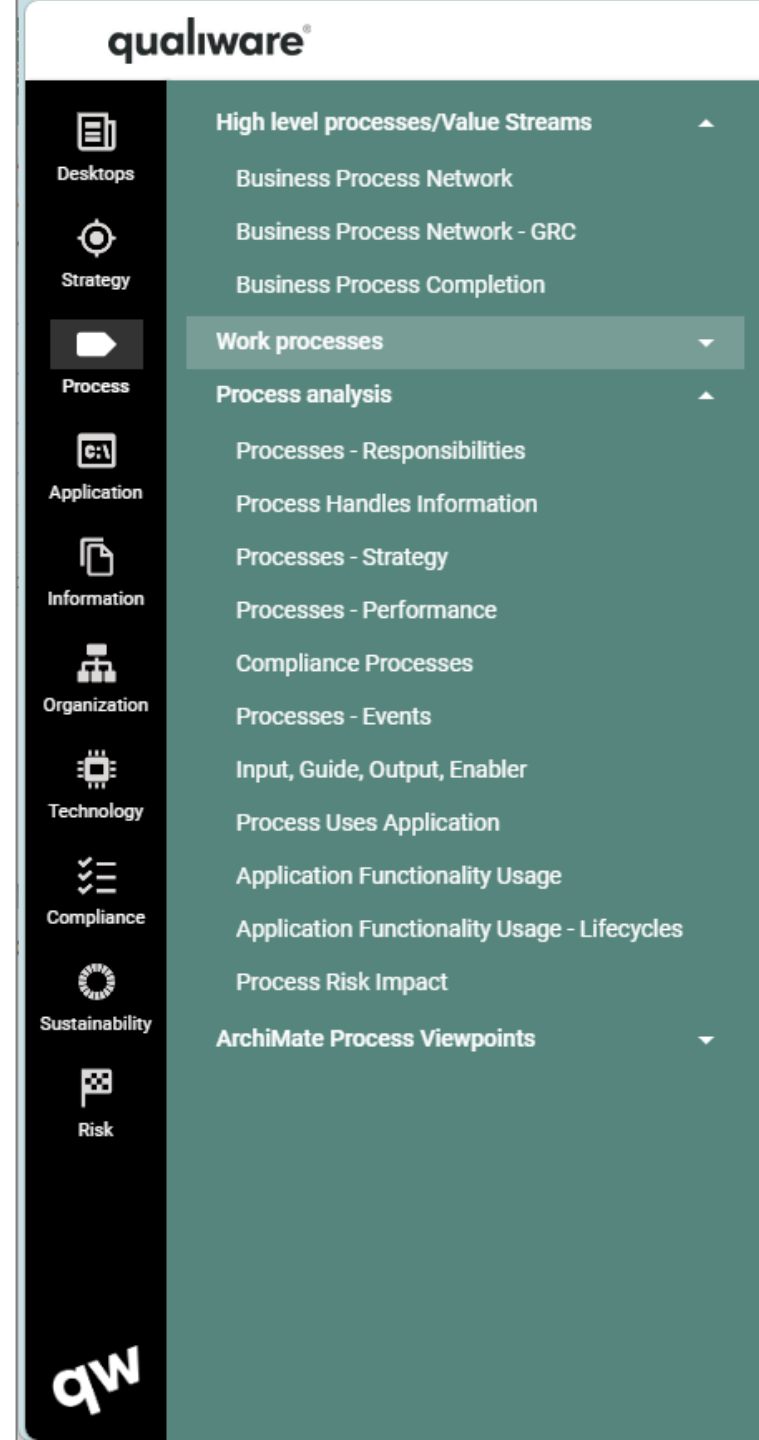

Desktops

The **Desktop** is the starting point, tailored to a specific area of the business.

- Each **desktop** is organised around a purpose — for example, Process Management, Application Management, or Compliance — and gives you a single place to explore, analyse, and work with the content in that area.
- Every user has a **Personal Desktop** as their default starting point. It contains tiles and content that your organisation has set up for your role. From there you can navigate to any of the specialist desktops via the tabs across the top of the screen or through the left menu.

See more about the [Desktops on our Center of Excellence](#)

The screenshot displays the Qualware Business Process Management (BPM) desktop interface. The interface is organized into several key sections:

- Navigation:** A top bar with tabs for USER DESKTOP, COMPLIANCE, APPLICATION MANAGEMENT, PROCESS MANAGEMENT, and RISK MANAGEMENT. A left sidebar provides quick access to various functional areas like Strategy, Process, Application, Information, Organization, Technology, Compliance, Sustainability, and Risk.
- Top process:** A central flowchart showing a sequence of business processes such as 'Manage Financial Resources', 'Manage and control business', 'Financial Statement Close', 'Purchase product', 'Market product and service', 'Provide product', 'Perform overhaul', 'Manage human resources', 'Handle payment', and 'Manage infrastructure'.
- Getting started:** A menu with options like Import, Create Business Process content, Edit Business Process content, View Business Process content, and Approach to Business Process Management.
- Process hierarchy:** A tree view showing the organizational structure of processes, including categories like 'Chixi Car Rental Processes', 'Financial Statement Close', 'Handle payment', 'Manage and control the business', 'Manage Human Resources', 'Manage infrastructure', 'Market product and service', 'Perform overhaul', 'Provide Car Rental Service', 'Book car', 'Perform overhaul', 'Perform service', 'Purchase car', 'Chixi Process Overview', and 'Wayfinding'.
- Process News:** A feed of updates, including 'Local Process News' and 'Something exiting'.
- Business Process Network - Go...:** A chart showing the status of processes (Approved, Development, Finished, Ready for approval).
- Work Flow Dia. - Gov. State:** A chart showing the status of work flow diagrams.
- Bus. Process Dia. - Gov. state:** A chart showing the status of business process diagrams.
- Operating Model:** A detailed diagram of the 'Chixi Overview Business Operating Model'.
- Top Value chain model:** A diagram illustrating the value chain model, showing the flow from 'Manage Financial Resources' to 'Provide product'.

Workspace - Each Desktop is organised around a purpose

Select desktops by clicking the +

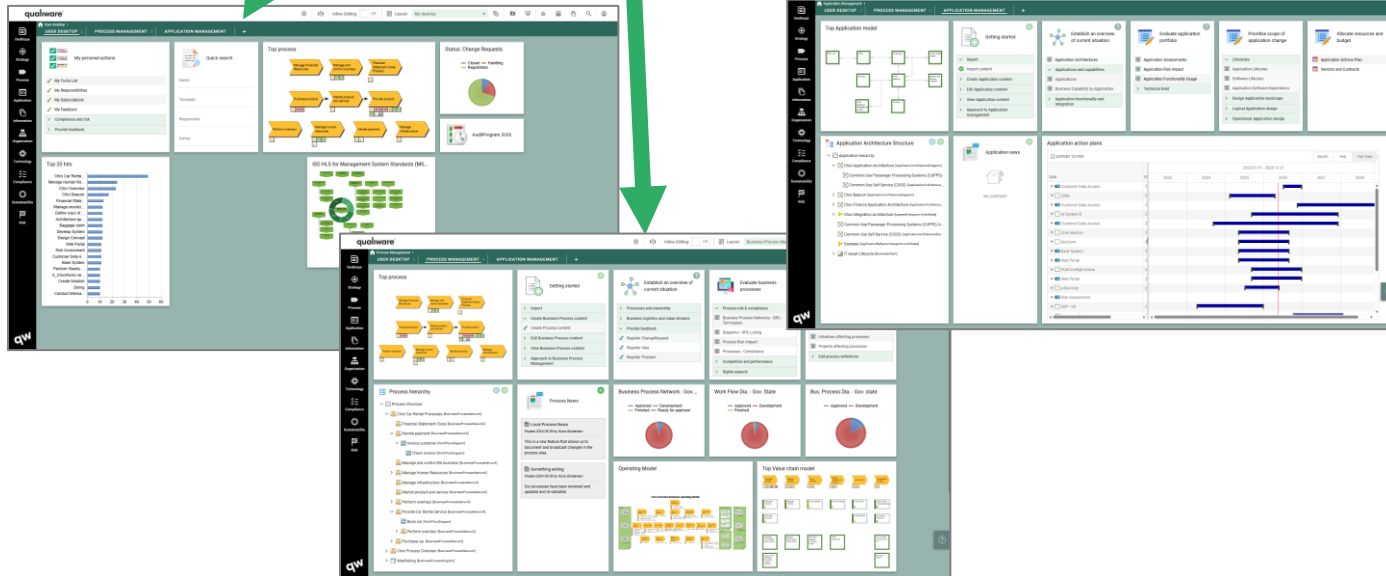
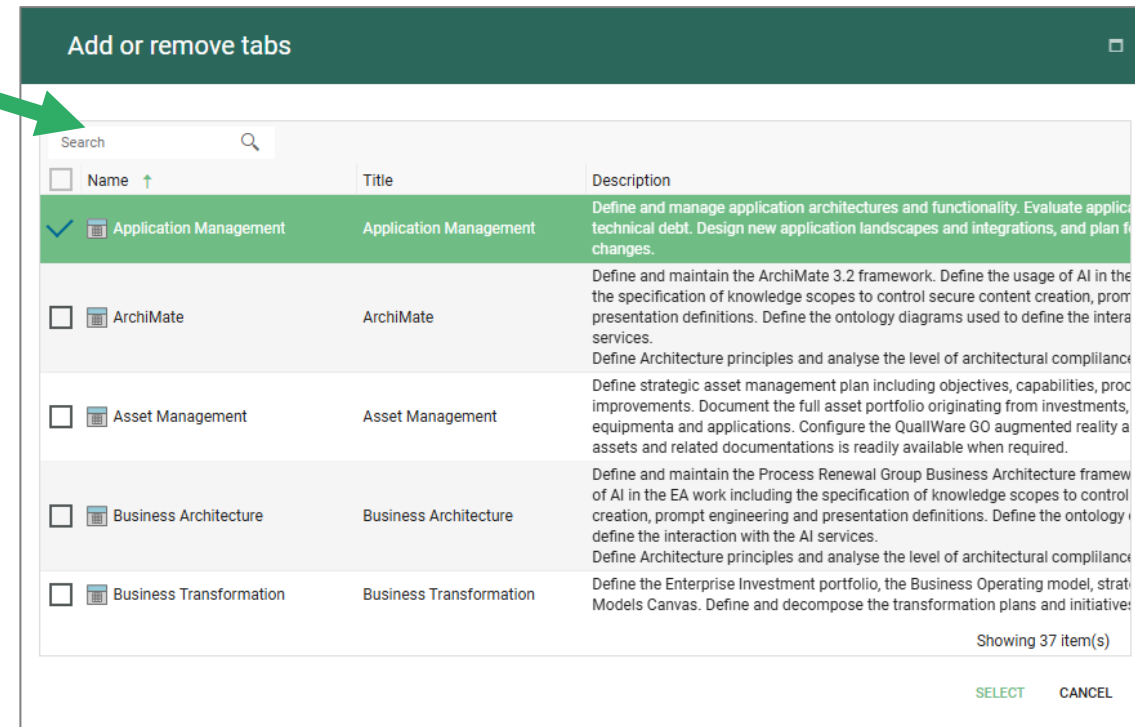
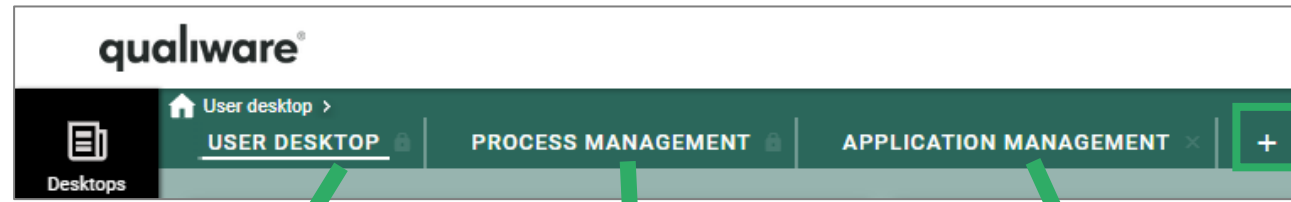

Each desktop is organised around a purpose — for example, Process Management, Application Management, or Compliance — and gives you a single place to explore, analyse, and work with the content in that area.

All desktops can be configured for different users and roles. On top of that, each end-user can create a **personal layout** for each desktop by hiding, re-sizing and/or re-organizing the tiles by drag and drop.

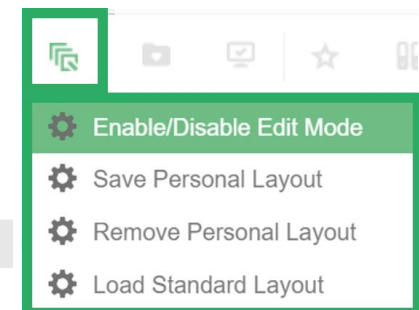

Journey based desktop have a standard layout

The desktops are structured around the same high-level layout

1 **Top Diagram** for the content in the desktop

2 **Purpose based tiles**, that cover the whole journey within the purpose of the Desktop.

- from “**getting started**” to browsing, modifying, analysing, improving and monitoring the status.

3 **Hierarchy view**, collection of most relevant content within the desktop focus

4 **News section**, a “local” desktop news feed, where users can collaborate and share relevant news

5 **Metrics and additional diagrams**, showing KPIs, charts, and additional content

The screenshot displays the Qualware Capability Management desktop interface. The layout is organized into several sections:

- Top Diagram (1):** A large orange-bordered tile titled "Top Capability Model" showing a hierarchical diagram of capabilities.
- Purpose based tiles (2):** A row of five green-bordered tiles: "Getting started", "Establish an overview of current situation", "Assess capabilities", "Develop capability roadmap", and "Consolidate and communicate change initiatives".
- Hierarchy view (3):** A purple-bordered tile titled "Capability structure" showing a tree view of capabilities under "Chixi Core Capabilities".
- News section (4):** A blue-bordered tile titled "Capability news" with a "Key capabilities" update.
- Metrics and additional diagrams (5):** A large green-bordered tile titled "Attention required" containing a table of capabilities and their maturity levels, and three pie charts on the right showing "Delivered by Process", "Delivered by Investments", and "Delivered by Application".

Capability:	Overall Importance:	Overall Maturity:	Target Maturity:
AI	5. Differentiator	1. Adhoc	4. Measured
Manage Customers	5. Differentiator	1. Adhoc	3. Consistent
Online Product Catalog	5. Differentiator	1. Adhoc	2. Inconsistent
Mobile personalization solution	5. Differentiator	1. Adhoc	3. Consistent
Customer Requirements and Research	5. Differentiator	1. Adhoc	4. Measured
Traveller Behavior Intelligence	5. Differentiator	1. Adhoc	3. Consistent
Passenger dwell/transit	5. Differentiator	1. Adhoc	2. Inconsistent
Digital Tags	5. Differentiator	2. Inconsistent	2. Inconsistent
Beacon Technology Platform	5. Differentiator	2. Inconsistent	4. Measured
Sell Services	5. Differentiator	2. Inconsistent	4. Measured

Delivered by Process: 29.05% Delivered, 70.94% Not Delivered

Delivered by Investments: 54.70% Delivered, 45.30% Not Delivered

Delivered by Application: 34.19% Delivered, 65.81% Not Delivered

Getting Started – Easy access to..

- **Importer** enabling you to import existing content from other sources via e.g. CSV-files
- **Create content**, displays a list of relevant model types within the focus area of the desktop, allowing you to create new models within the scope of the desktop
- **Edit content**, displays a searchable list of existing models within the focus area of the desktop, allowing you to edit existing models within the scope of the desktop
- **Visualize content**, displays a searchable list of existing models within the focus area of the desktop, allowing you to visualize existing models within the scope of the desktop
- **Approach to ...**, contains a set of references to methodological content on QualiWare's Center of Excellence and/or other sources (where relevant)

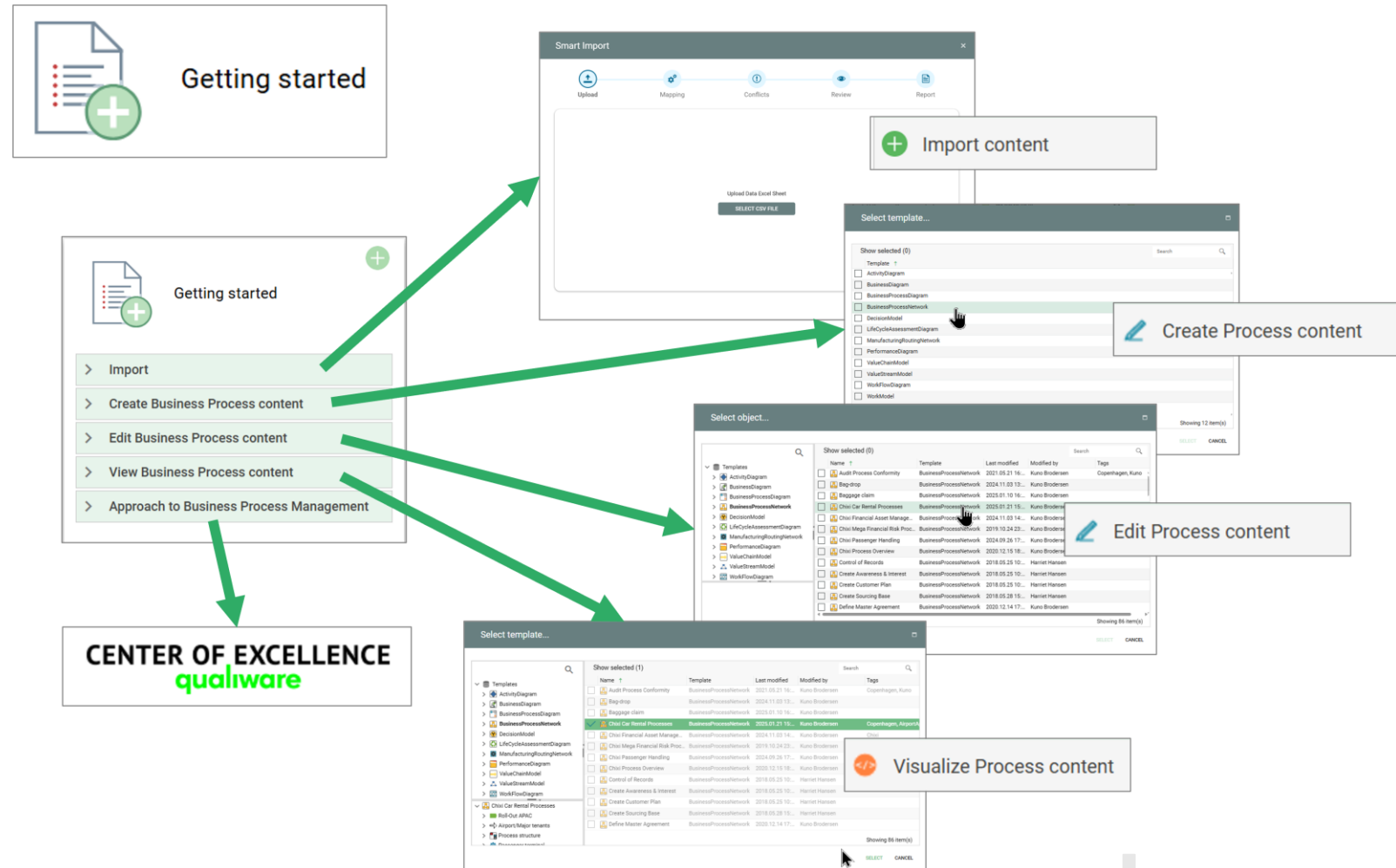

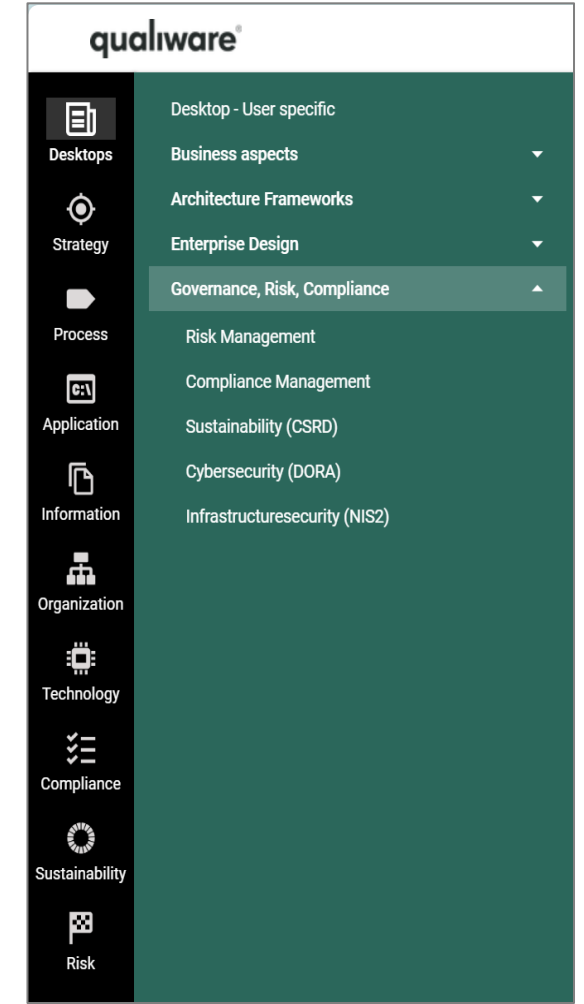
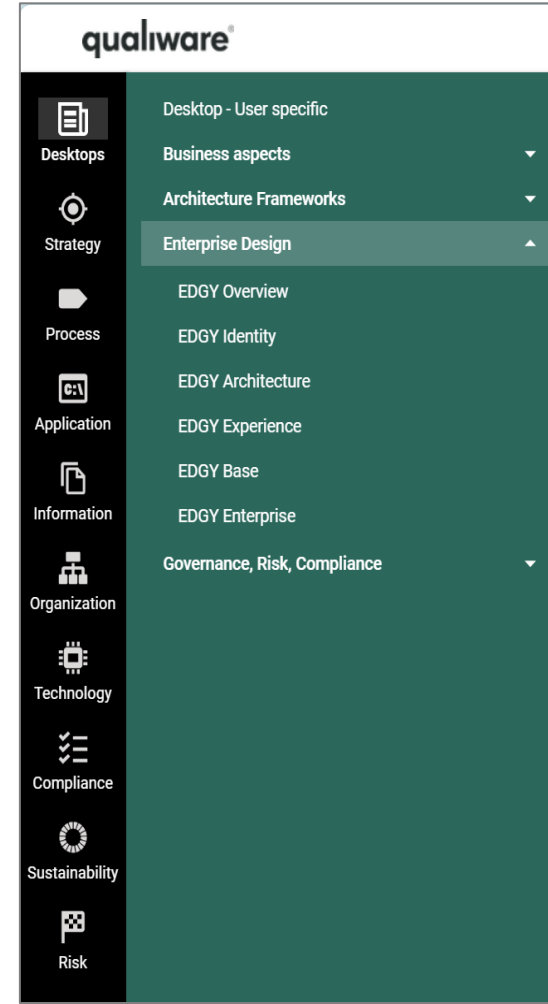
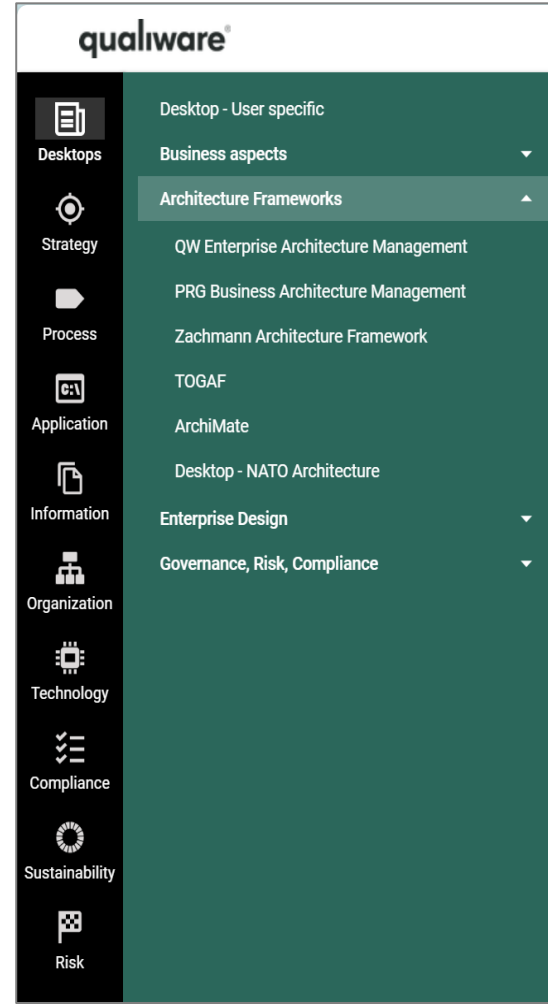
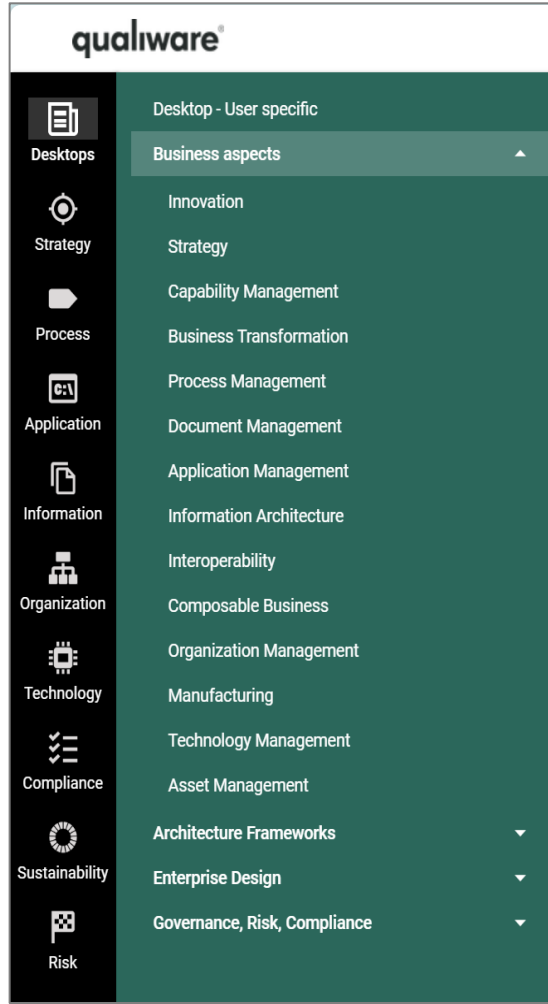

Standard Desktops are available in the Menu



Personal Desktop

Your Personal Desktop is your home base. It starts with the content your organisation has configured for your role

- **My Personal Actions** — a tile that lists your To-Do items, responsibilities, subscriptions, feedback, and compliance items
- **Pin content** — from any diagram, use the “Pin to my desktop” button in the toolbar to add it to your Personal Desktop.
- **Add tiles** — from any desktop, you can pin individual tiles (such as a process hierarchy or a KPI chart) to your personal desktop.
- Each user can **personalize** their desktops by hiding, re-sizing and/or re-organizing the tiles by drag and drop.

My personal actions

- ✓ My To-Do List
- ✓ My Responsibilities
- ✓ My Subscriptions
- ✓ My Feedback
- > Compliance and risk
- > Provide feedback

qualware

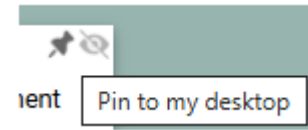
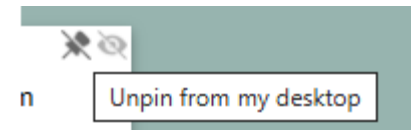
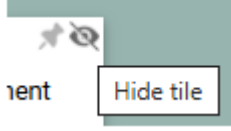
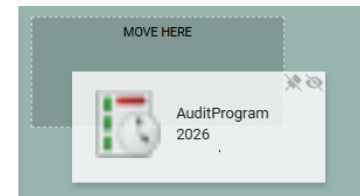
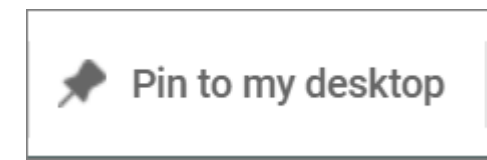
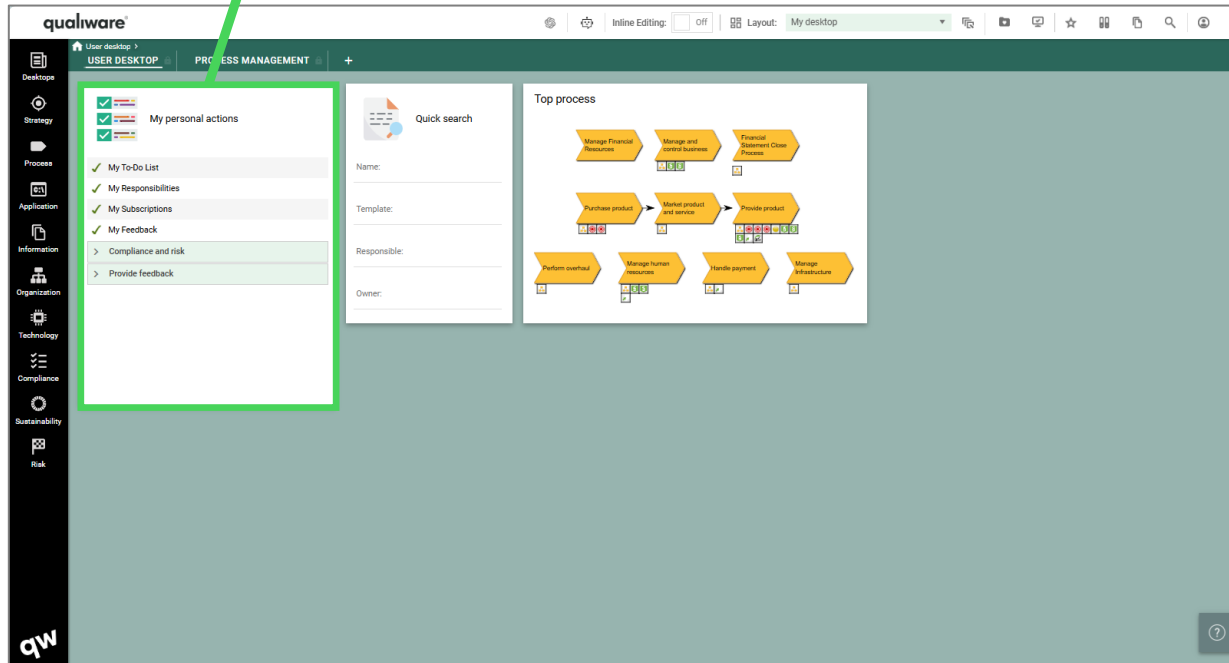
USER DESKTOP | PROCESS MANAGEMENT

My personal actions

- ✓ My To-Do List
- ✓ My Responsibilities
- ✓ My Subscriptions
- ✓ My Feedback
- > Compliance and risk
- > Provide feedback

Quick search

Name: _____

Template: _____

Responsible: _____

Owner: _____

Top process

```

    graph LR
      A[Manage Financial Resources] --> B[Manage and control business]
      B --> C[Financial Statement Close Process]
      D[Purchase product] --> E[Market product and service]
      E --> F[Provide product]
      G[Perform overhaul] --> H[Manage human resources]
      H --> I[Handle payment]
      I --> J[Manage Infrastructure]
    
```

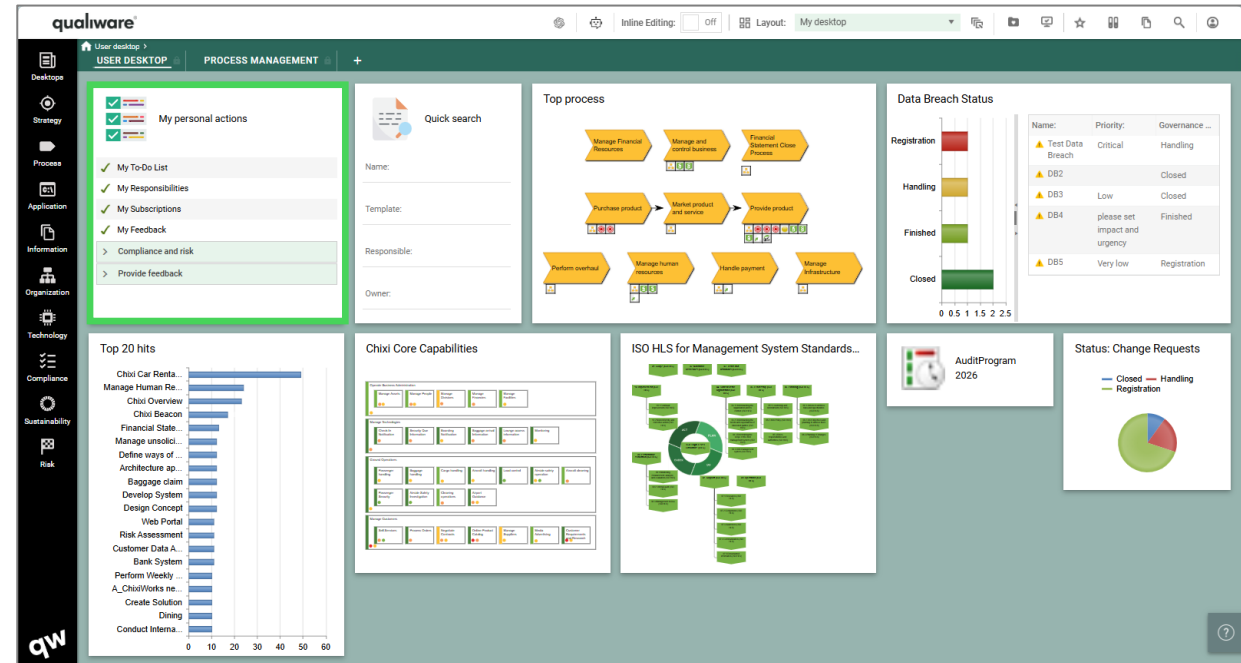

qualware

USER DESKTOP | PROCESS MANAGEMENT

My personal actions

- ✓ My To-Do List
- ✓ My Responsibilities
- ✓ My Subscriptions
- ✓ My Feedback
- > Compliance and risk
- > Provide feedback

Quick search

Name: _____

Template: _____

Responsible: _____

Owner: _____

Top process

```

    graph LR
      A[Manage Financial Resources] --> B[Manage and control business]
      B --> C[Financial Statement Close Process]
      D[Purchase product] --> E[Market product and service]
      E --> F[Provide product]
      G[Perform overhaul] --> H[Manage human resources]
      H --> I[Handle payment]
      I --> J[Manage Infrastructure]
    
```

Top 20 hits

Item	Count
Chivi Car Rental	50
Chivi Beach	45
Chivi Overview	40
Financial State	35
Manage unsolic...	30
Architecture ap...	25
Baggage claim	20
Develop System	15
Design Concept	10
Web Portal	5
Risk Assessment	5
Customer Data A...	5
Bank System	5
Perform Weekly...	5
A_ChiviWorks me...	5
Create Solution	5
Dining	5
Conduct Interna...	5

Chivi Core Capabilities

ISO HLS for Management System Standards...

Data Breach Status

Registration	Handling	Finished	Closed
0	1	1	1

Name	Priority	Governance
▲ Test Data Breach	Critical	Handling
▲ DB2	Low	Closed
▲ DB3	Low	Closed
▲ DB4	please set impact and urgency	Finished
▲ DB5	Very low	Registration

AuditProgram 2026

Status: Change Requests

- Closed
- Handling
- Registration

Standard desktops

- QualiWare consist of more than 30+ standard desktops available out of the box

See more about the [Desktops on our Center of Excellence](#)

- Explore the list of available standard desktops: [Desktops | QualiWare Center of Excellence](#)

The screenshot displays the 'CENTER OF EXCELLENCE' page for QualiWare. The header includes the QualiWare logo, navigation links for 'Solutions', 'Library', and 'Academy', and a search icon. The main heading is 'Explore the standard Desktops', followed by a sub-heading: 'As standard QualiWare contains a new set of desktops, read more about the desktops below.' Below this is a filter bar with 'All' selected and other categories: 'Architecture Framework Desktop', 'Business Aspects Desktop', 'Enterprise Design Desktop', and 'Governance-Risk-Compliance Desktop'. The main content area features a grid of eight desktop preview cards, each with a 'Read more' button. The desktops shown are: Innovation Desktop, Strategy Desktop, Capability Management Desktop, Business Transformation Desktop, Process Management Desktop, Application Management Desktop, Information Management Desktop, and Interoperability Desktop.

The desktop provides access to all types of content

Personal lists

Queries and analysis

Other types of content

The Qualiware User Desktop dashboard is a central hub for process management. It features a left sidebar with navigation icons for Deskspace, Strategy, Process, Information, Organization, Compliance, and Sustainability. The main area is divided into several sections: 'My personal actions' with a checklist of tasks like 'My To Do List', 'My Responsibilities', and 'My Subscriptions'; a 'Quick search' section with fields for Name, Template, Responsible, and Owner; a 'Top process' section displaying a flowchart with steps like 'Manage Financial Resources', 'Manage and control business', and 'Financial Statement Close Process'; an 'Evaluate business processes' section with a tree view of categories like 'Process risk & compliance' and 'Business Process Networks - GRC - Terminated'; and an 'AuditProgram 2026' section with a calendar icon.

This detailed view of the 'Evaluate business processes' section shows a table of process risks. The table has columns for 'Type', 'Process', 'Status', 'Risk Level', 'Impact', and 'Control Measures'. The rows are color-coded by risk level, with red for high risk and green for low risk. A sidebar on the right provides a summary of the data.

This view shows a detailed diagram of an application architecture. The diagram consists of various components like 'ERP-SD', 'CRM', 'HRM', and 'SCM' connected by lines. A sidebar on the right provides 'Properties' and 'Description' for the selected component. Below the diagram, there are sections for 'Status', 'Aligned with - Improving', 'Collaboration', 'Application report', and 'Improvement schedule'.

This view shows a detailed GRC dashboard. It features a 'GRC' header and a main area with a grid of charts and tables. The charts include 'System Health', 'System Risk', and 'System Compliance'. The tables show 'System Health - 10 Items', 'System Risk - 3 Items', and 'System Compliance - 2 Items'. A sidebar on the right provides a summary of the data.

Diagrams Dashboard

Dashboards (Diagram workspace)

It is possible to set up multiple layouts for a diagram type, e.g. **Browsing** view for content users; and **Analyzing and Improving** view for the content owner

- the dashboards can be customized by the user
- the content is responsive, showing associated data either for the diagram as a whole or for the selected object
- a set of new tiles have been added to provide easy access to associated features, well-known as well as cool new features
- Dashboards can also be used for non-graphical templates such as AuditProgram, ChangeRequests, Projects and many more

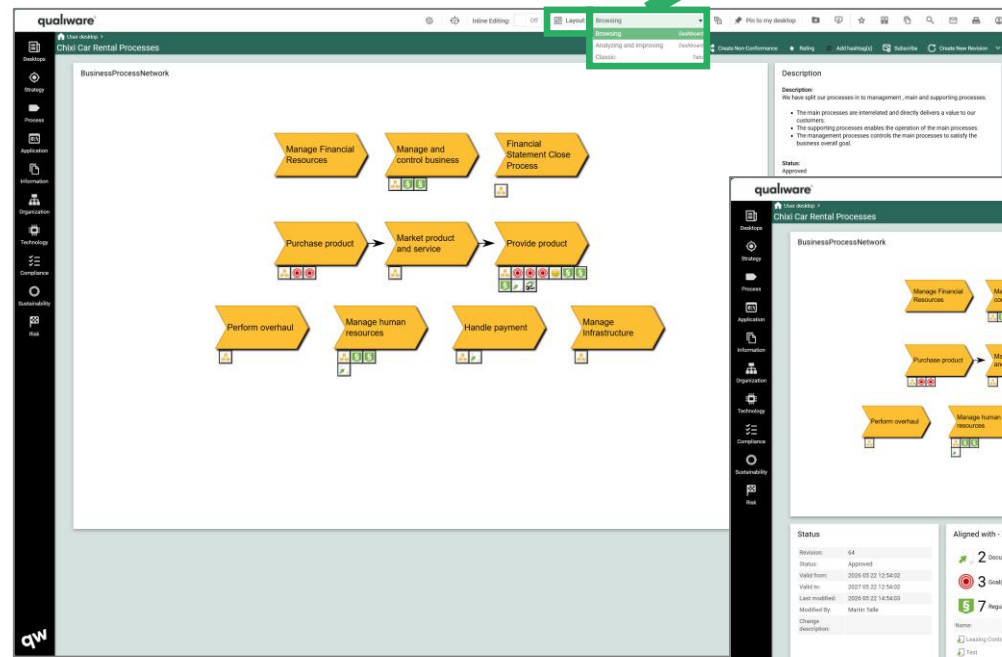
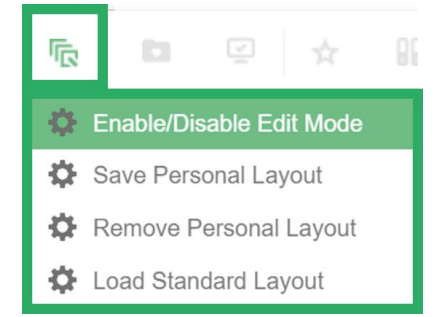
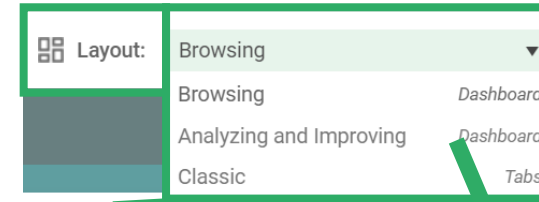

Browsing Dashboard

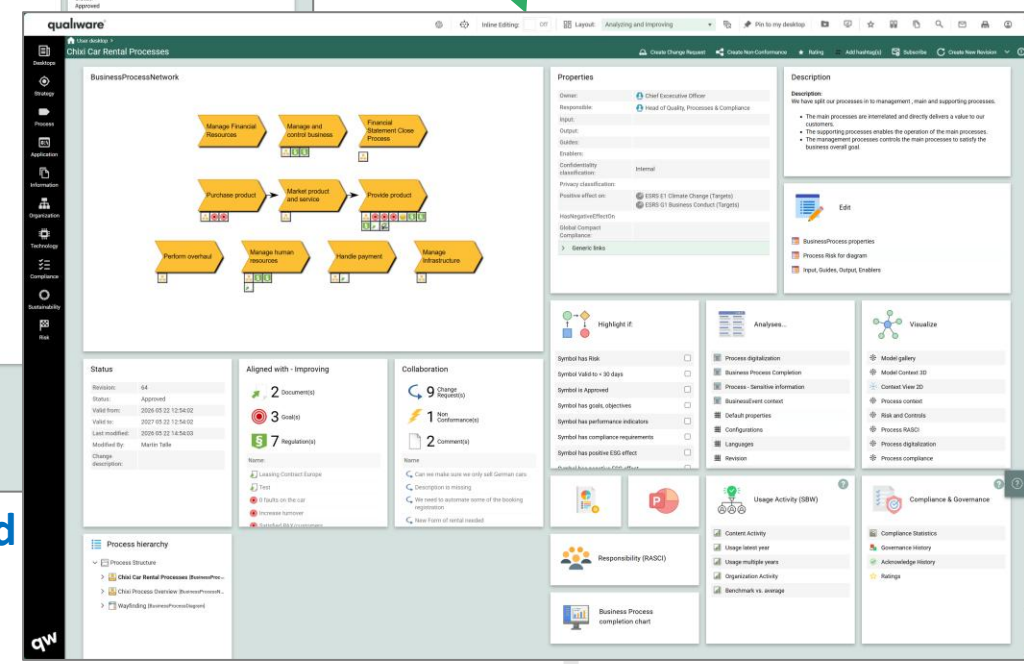

Analyzing and Improving Dashboard

See more about the [Dashboard feature on our Center of Excellence](#)

Classic Diagram workspace

Menu, Information-boxes and Business Information charts can be collapsed/shown

1

Collapsible boxes with information about diagram and symbols

2

Extended action button list

3

Diagram-specific actions (governance actions and features)

4

Business information charts

5

Tabs with specific diagram information, analytics and editing capabilities

6

Zooming and panning buttons

7

Layout menu (change to Dashboard)

qualiware

Chixi Car Rental Processes

Information

Responsible: Karen Vasquez
Accountable: Henrik Knudsen
Revision: 48
Last Modified: 2022 10 19
Status: Development

Documents

- Leasing Contract Europe (drq_workflow)
- QW Letter head

Goals

- 0 faults on the car
- Increase turnover
- Satisfied PAX/customers

Regulations

- ISO 9001:2008
- 05.1
- 05.2
- ISO/IEC 27001:2013 - 7.5 Documented information
- Law (1979:561) regarding car rental
- Law (1976:580) of influence in work
- Law (1982:80) of employment protection

Processes

- Handle payment
- Manage Infrastructure
- Manage and control business
- Manage human resources
- Market product and service
- Perform overhaul
- Provide product
- Purchase product

DIAGRAM DESCRIPTION BUSINESS PROCESSES RISKS RE-ARRANGE IGoe COMMENTS CHANGE REQUESTS NON-CONFORMANCES RASCI

Layout: Classic

Business Process Cost - Benefit

Business Process Cost - Benefit - Details

Business Process Totals

- Number of processes on diagram
- Total Cost of processes on diagram
- Average Cost of processes on diagram

Business Process Status

Capabilities Delivered by Business Process

Delivered: 84 Not Delivered: 38



QualiAI (QualiWare version 10.9)

- AI-generation of diagram and content QualiWare's Cutting-Edge Generative Artificial Intelligence
- **AI-Powered Diagram Creation:** With QualiAI, harness the power of artificial intelligence to automatically generate diagrams from various types of context, making the diagram creation process more efficient and user-friendly.
- **Intelligent Context Analysis:** QualiAI analyzes the given context to create initial diagram drafts, providing a valuable starting point and streamlining the diagramming process for creators.
- **KnowledgeScope Templates:** Utilize our innovative [KnowledgeScope](#) template to guide the AI, ensuring the diagrams generated meet your specific needs and context requirements.

A screenshot of the 'AI Query' interface. The window has a dark teal header with the title 'AI Query' and a close button. Below the header, there are three input fields: 'KnowledgeScope:' containing 'Generate WorkFlowDiagram', 'Context:' containing 'Book Car', and 'Input:' which is currently empty. At the bottom of the window, there are two buttons: 'Generate Diagram (Ctrl + G)' and 'Link Context'.

Read more about the [QualiAI on our Center of Excellence](#)

QualiChat (QualiWare version 10.10)



- The QualiChat is an AI Chatbot that has been embedded directly in QualiWare 10.10.
- This allows users to ask questions, analyze content, and explore repository data in a natural, conversational way.
- It is also possible to set up the Chatbot in your teams channel, so you can prompt it directly in the chat.

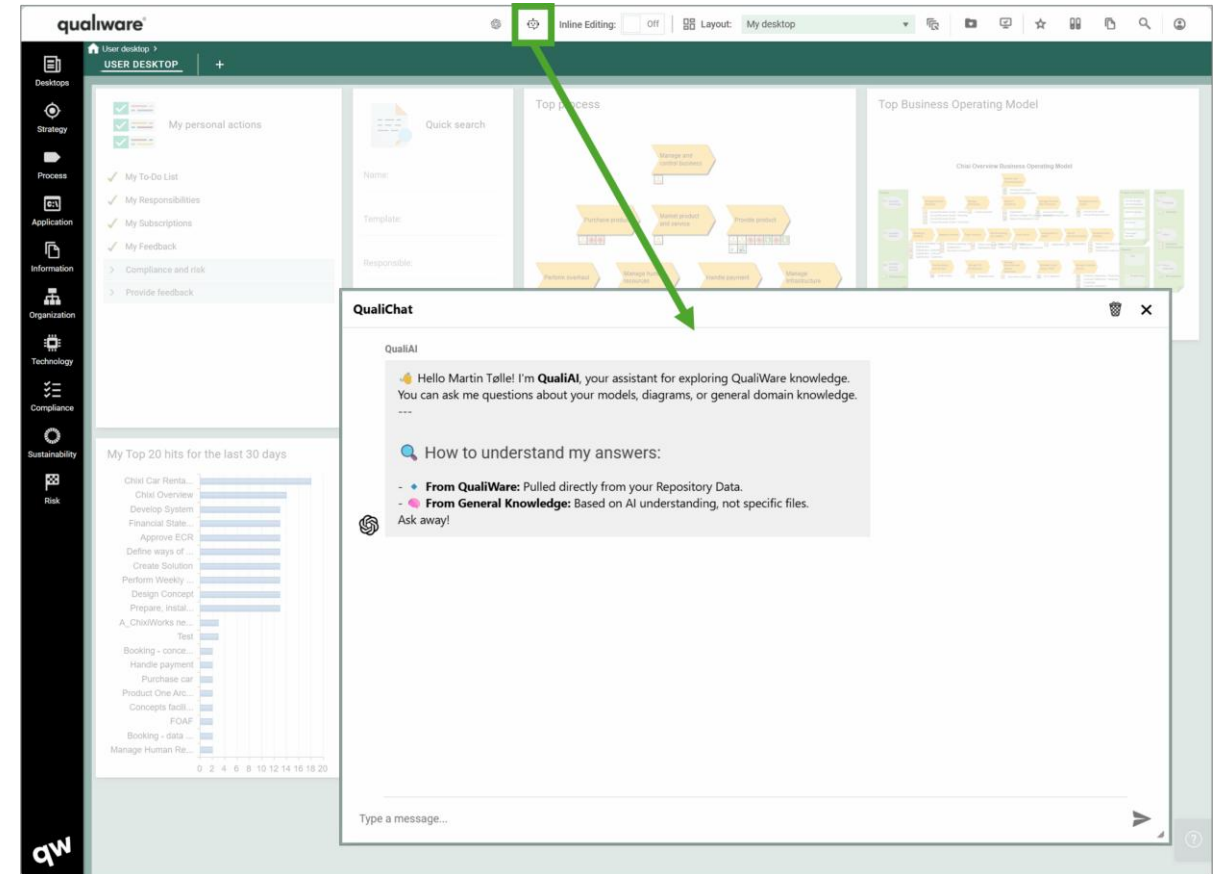
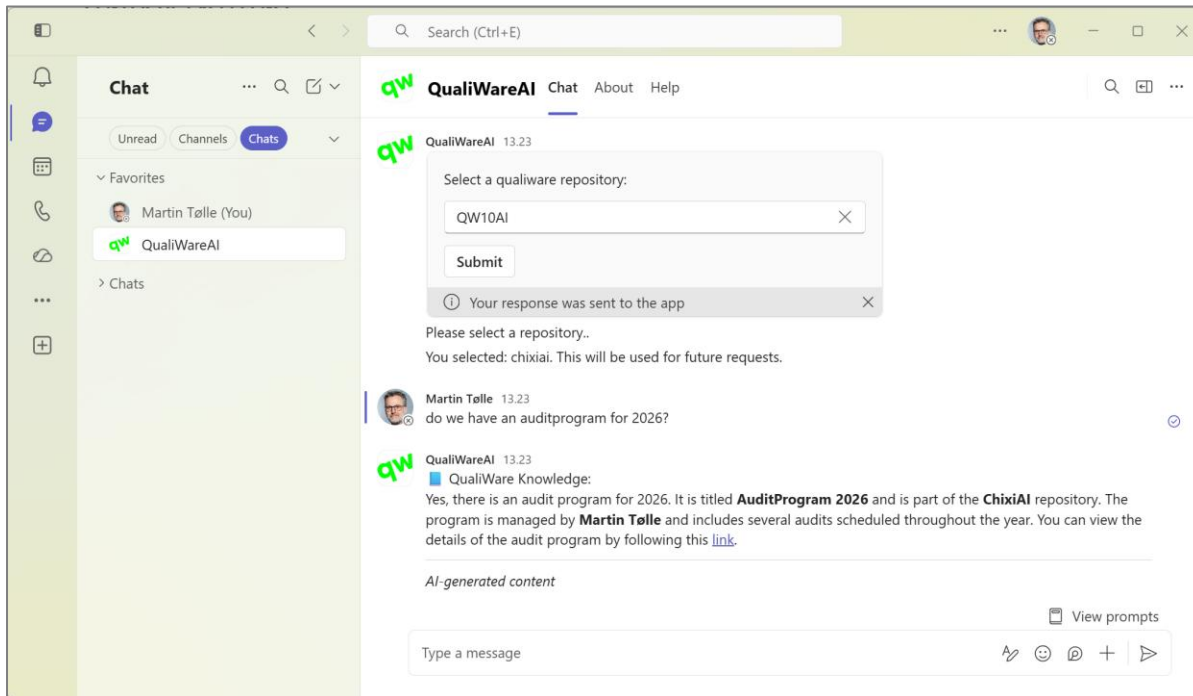

Read more about the [QualiChat on our Center of Excellence](#)

Workspace – Toolbar

See more about the [Toolbar on our Center of Excellence](#)

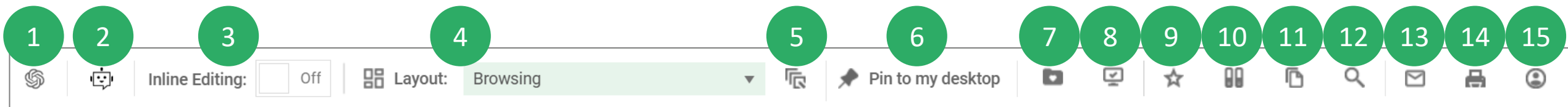

1.	QualiAI	Generate and enrich your content using AI
2.	QualiChat	AI chatbot where you can chat about the content in your own natural language
3.	Inline Editing	Toggle on/off to enable editing the property directly in the tiles
4.	Layout	Change between available layout (Dashboard(s) and Classic views)
5.	Personal Layout	Create a personal layout and save it and/or load standard
6.	Pin to my desktop	Pin the content to your personal desktop
7.	My Subscriptions	Show your subscriptions (personal as well those managed by your organization)
8.	'To-do' list	Your To-Dos, sorted by their underlying governance flow and governance state
9.	Latest viewed objects	Most recent diagrams viewed by the user
10.	Repository Explorer	Explore and search content in the repository
11.	Repository Compare	Compare content between two different repositories or configurations
12.	Search	Open Free Text Search
13.	Share	Share this page, send an email with a direct link to the content your are viewing
14.	Print	Choose between available "Print reports" available for the template type you are viewing
15.	User Profile	Shift between available roles, configurations and languages, and logout

Content of toolbar changes depending on context and user access



QualiHelp (QualiWare version 10.9)



Do you need help using QualiWare?

QualiWare's Innovative Dynamic Help Widget

- Inside the Web-Modeler
 - **User-Centric Design:** Designed with you in mind, QualiHelp delivers timely and relevant assistance when creating the diagram.
 - **Smart Context Recognition:** Working on a diagram in the web-modeler? QualiHelp discerns the context and swiftly retrieves the relevant guides for you.
 - **Comprehensive Guidance:** Be it the diagram, symbols, or connections, QualiHelp ensures you're equipped with the right information every time.
- Outside the Web-Modeler
 - **Extended Support:** QualiHelp serves as a comprehensive resource center, providing easy access to a wide range of QualiWare tools and resources, catering to diverse user needs beyond the Web-Modeler.
 - **Static Resource Access:** This mode offers direct links to essential resources such as Getting Started guides, FAQs, and the latest QualiWare updates, ensuring key information is readily available.
 - **Consistent User Experience:** QualiHelp ensures a uniform, user-friendly experience across the QualiWare platform, offering the necessary support and information regardless of where you are in your QualiWare journey.

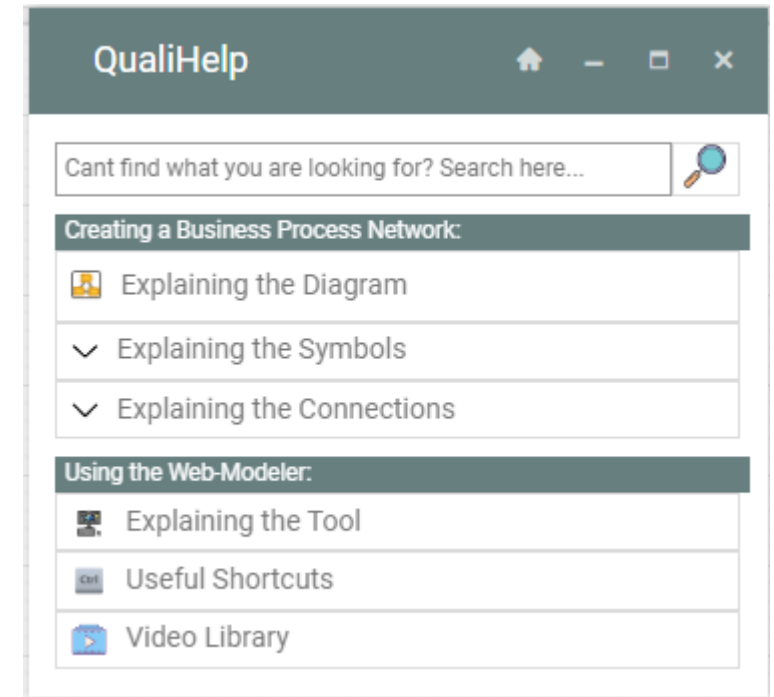

Read more about the [QualiHelp on our Center of Excellence](#)

qualiware



How to draw a diagram

Introduction to the Webmodeler

qualiware

Process modeling

Process modeling focuses on events, processes and their sequence.

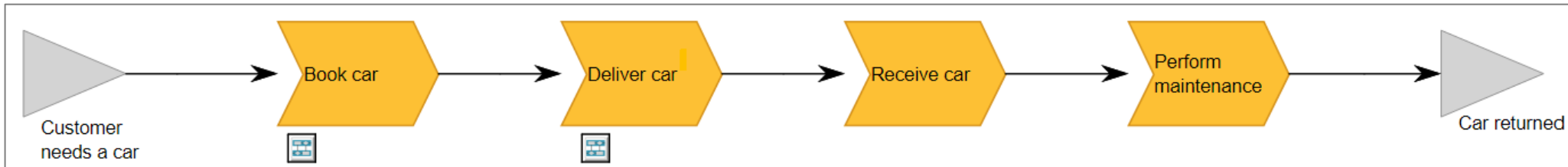

Create a new diagram

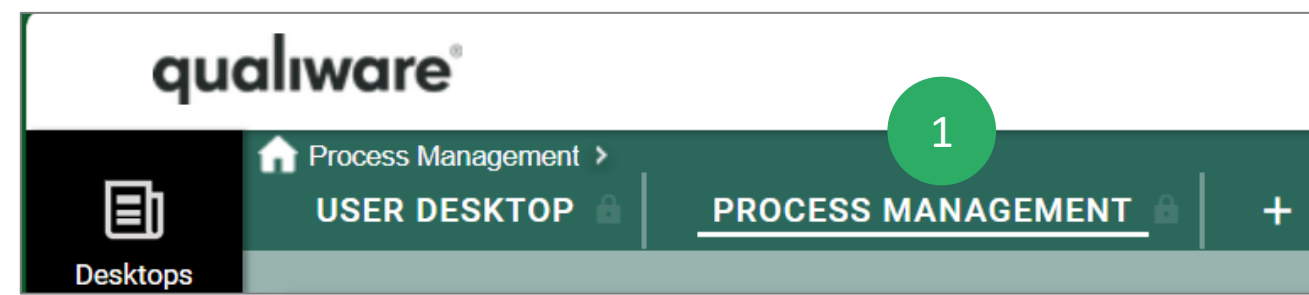

- 1 Open the relevant desktop (Process Management)
- 2 From the Getting started tile – Click 'Create Process content'
- 3 Select template 'Business Process Network'
- 4 Enter the name of your diagram and select 'CREATE'

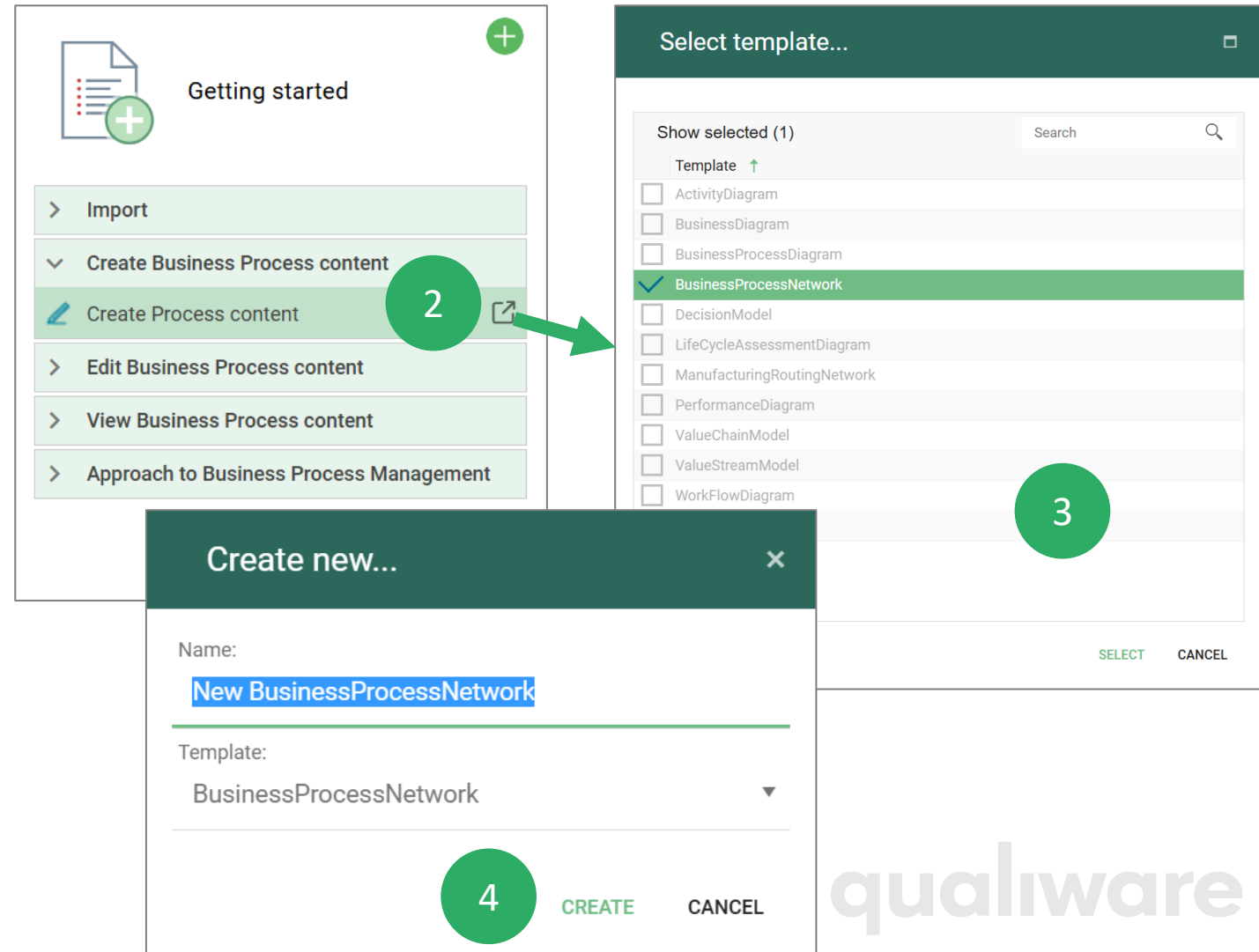

Web-Modeler

The image shows the Qualiware Web-Modeler interface for managing human resources. The main workspace displays a BPMN diagram for the process "Introduce new employee". The interface is annotated with several callouts:

- Editing Toolbar:** A horizontal bar at the top containing various icons for editing and navigation.
- Layout Panel:** A panel on the top right with icons for AI and chat, and a "Layout:" dropdown menu.
- QualiAI:** An icon representing AI capabilities.
- QualiChat:** An icon representing chat functionality.
- Import:** A button for importing models.
- Menu:** A vertical sidebar on the left with options for Symbols, Explorer, and Settings.
- Symbol bar:** A panel below the menu showing symbols for BusinessProcess, BusinessEvent, BusinessObject, InformationSystem, BusinessScope, and WorkflowCondition.
- Governance:** A panel on the right showing details for the selected process, including owner, responsible, and resources.
- Property Filter:** A filter for the process properties.
- Property Window:** A window for viewing and editing process properties.
- QualiHelp:** A help icon in the bottom right corner.

The BPMN diagram in the center shows the following flow:

- Start event: Need of recruitment
- Task: Manage unsolicited applications
- Task: Recruit staff
- Event: Employee hired
- Task: Introduce new employee (highlighted with a dashed border)
- Event: Employee introduced
- Task: Develop employee competence
- Event: Employee competence developed
- Task: End employment
- Event: Employment ended

At the bottom of the workspace, there is a zoom slider ranging from 0 to 500.

Add a symbol

1 Drag with your left mouse button a symbol (a BusinessProcess) from the symbol bar and release the button where you wish to place the symbol (or double-click on the white canvas for a list of available symbols)

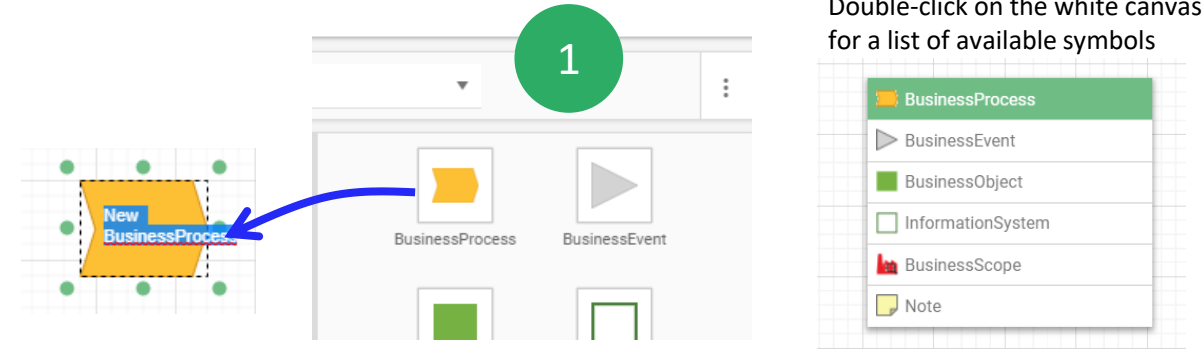

2 Give the BusinessProcess a name. Once 3 or more characters of the name are typed, a “search-box” will appear showing all similar objects in the repository of the selected type (BusinessProcess). This enables reuse of objects and/or having unique object names in the repository.

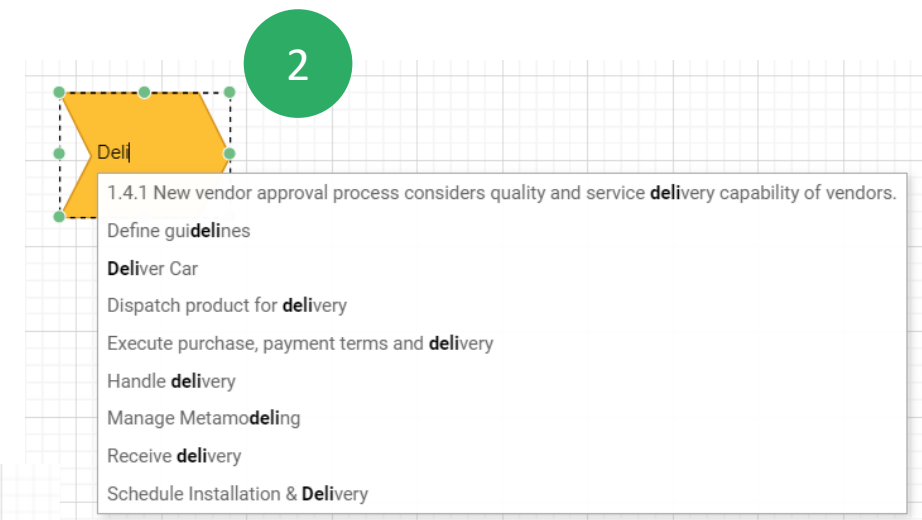

3 Alternatively hover over a BusinessProcess you wish to repeat/clone and click one of the four arrows

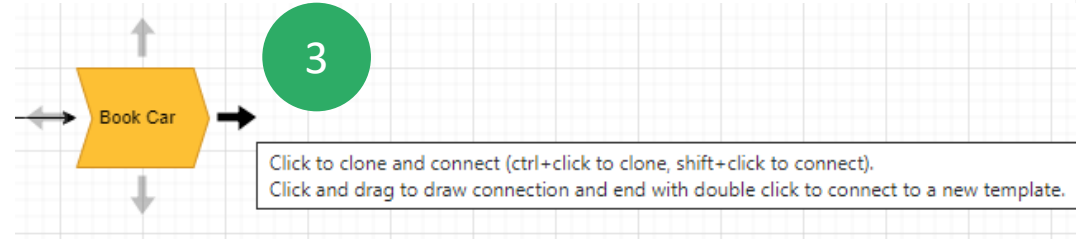

4 A new BusinessProcess will appear. If multiple connection-types are allowed between the two symbols, select the desired connection-type from the menu. Then double click the label and name the new BusinessProcess.

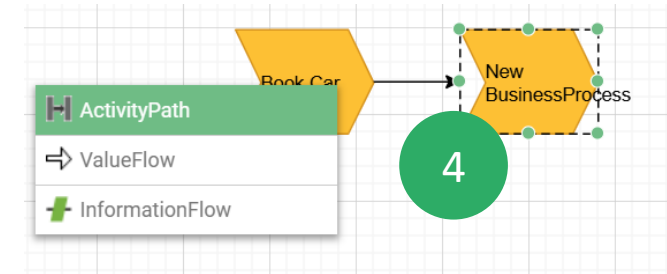

Re-using symbols

1 Select the BusinessProcess and double click the name to highlight the text

2 Right click the name to open a list of existing business processes

3 Browse the list to find the BusinessProcess you're looking for. Try to sort the columns differently by clicking the column header or enter a searchstring in the search field to narrow down you last.

4 Select the desired BusinessProcess or click 'Create New' if you didn't find what you were looking for.
Finish by clicking 'Select' to return the selected BusinessProcess to the diagram

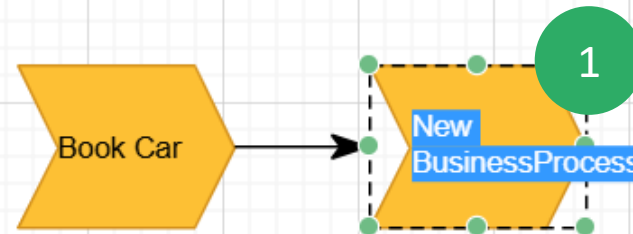

The screenshot shows a 'Select BusinessProcess' dialog box. On the left, a tree view shows 'Templates' > 'BusinessProcess' > 'Deliver Car'. The main area is a table with columns: Name, Template, Last modified, Modified by, and Tags. The 'Deliver Car' row is highlighted. At the bottom, there are buttons for 'CREATE NEW', 'SELECT', and 'CANCEL'. A green circle with the number '2' is above the dialog title, and a green circle with the number '3' is above the table. A green circle with the number '4' is above the 'SELECT' button.

Name	Template	Last modified	Modified by	Tags
<input type="checkbox"/> Book Car	BusinessProcess	2025.11.21 13:...	QualiWare Administrator	
<input type="checkbox"/> Cargo Handling	BusinessProcess	2018.05.25 09:...	Harriet Hansen	
<input type="checkbox"/> Chixi Car Rental	BusinessProcess	2026.02.20 15:...	Martin Tølle	
<input type="checkbox"/> Classify Cargo	BusinessProcess	2018.03.16 10:...	Harriet Hansen	
<input type="checkbox"/> Clean the car	BusinessProcess	2021.04.20 01:...	Kuno Brodersen	
<input type="checkbox"/> Control Cargo	BusinessProcess	2018.03.16 10:...	Harriet Hansen	
<input checked="" type="checkbox"/> Deliver Car	BusinessProcess	2025.11.21 13:...	QualiWare Administrator	
<input type="checkbox"/> Handle unclaimed cargo	BusinessProcess	2018.03.16 10:...	Harriet Hansen	
<input type="checkbox"/> Inspect the car	BusinessProcess	2017.09.29 02:...	QualiWare Administrator	
<input type="checkbox"/> Load Cargo	BusinessProcess	2018.03.16 10:...	Harriet Hansen	
<input type="checkbox"/> Park car	BusinessProcess	2017.09.29 02:...	QualiWare Administrator	
<input type="checkbox"/> Receive Car	BusinessProcess	2025.11.21 13:...	QualiWare Administrator	
<input type="checkbox"/> Sort Cargo	BusinessProcess	2018.03.16 10:...	Harriet Hansen	



Connecting existing symbols

1

Hover the source symbol and select the arrow on the side of the symbol where the connection should start.

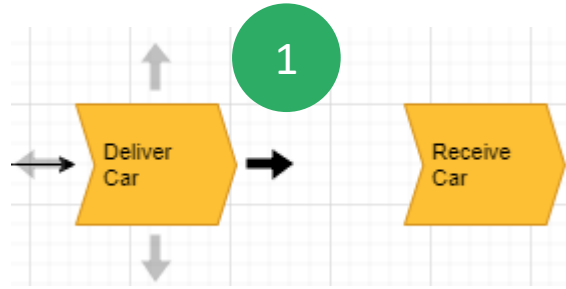

2

Drag the arrow with the left mouse button and release it on top of the target symbol

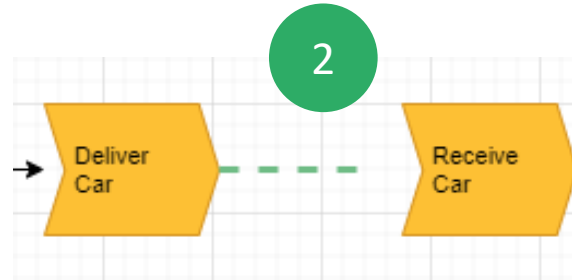

3

Select the desired connection type from the popup menu

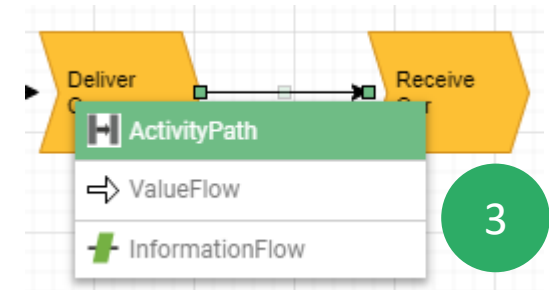

4

Use the green selector points on the connection to move sections of the connector to different positions

Tip: To find the easiest route between two symbols just select the connection and press the 'Space' key

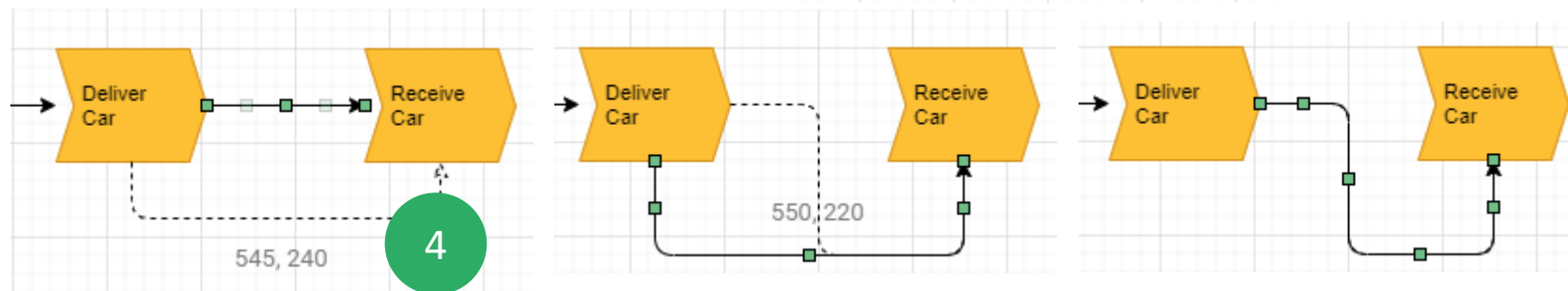

Deleting objects

- Select the symbol, select **Delete** key or the icon 'Delete selected' to remove the object from the diagram

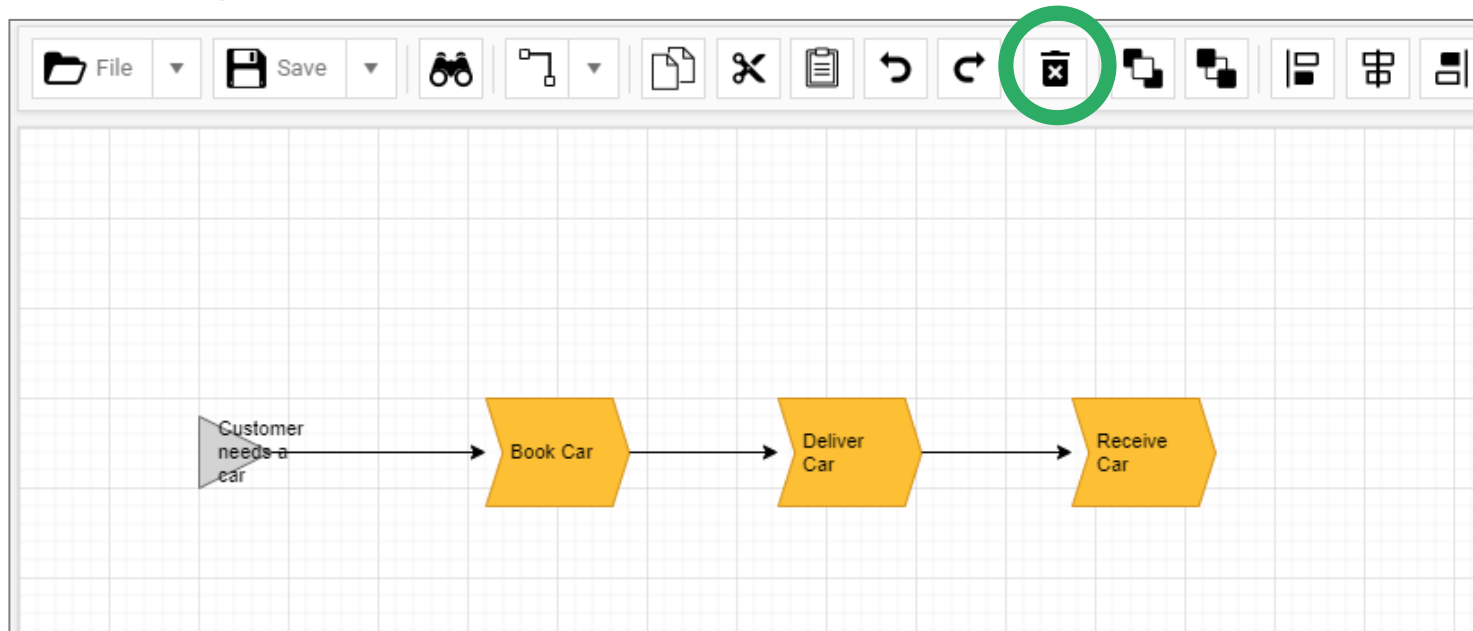

- Note: This will only remove the object from the diagram. To delete an object from the Repository go to the Repository Explorer, find the object and delete it using the context menu

Editing

The toolbar contains buttons for editing functionality

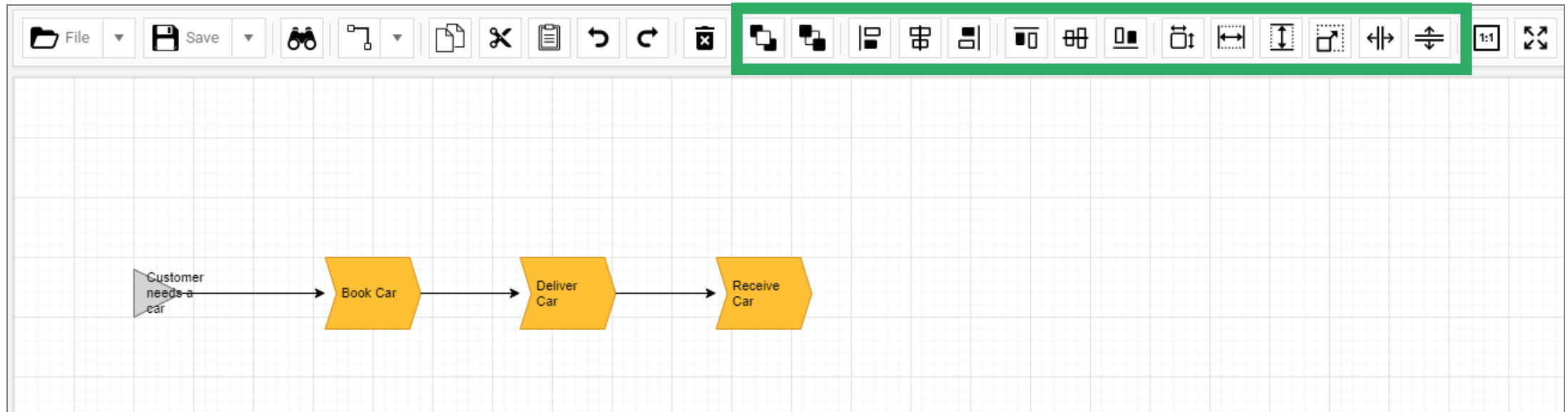

Symbol size

- You can change the size of any symbol.
- Select the object, get hold of a node and drag to desired size.

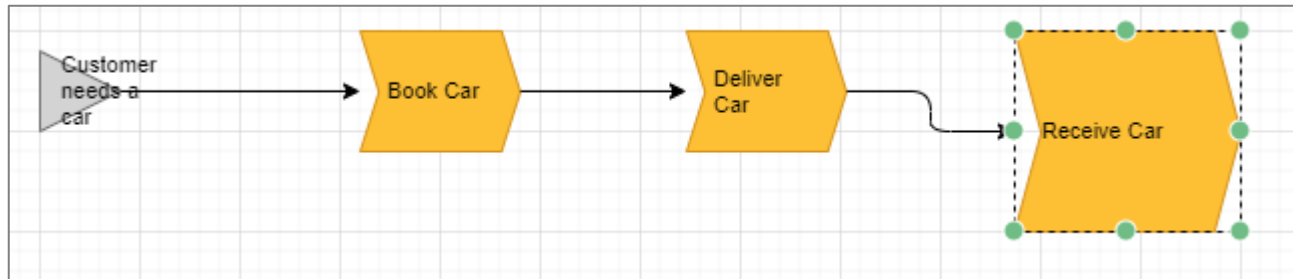

Sizing

- Use the buttons in the toolbar to align symbols
 - First select the controlling symbol (the symbol with the correct size/width/height. Then hold the shift key down and select the symbols you wish to change.

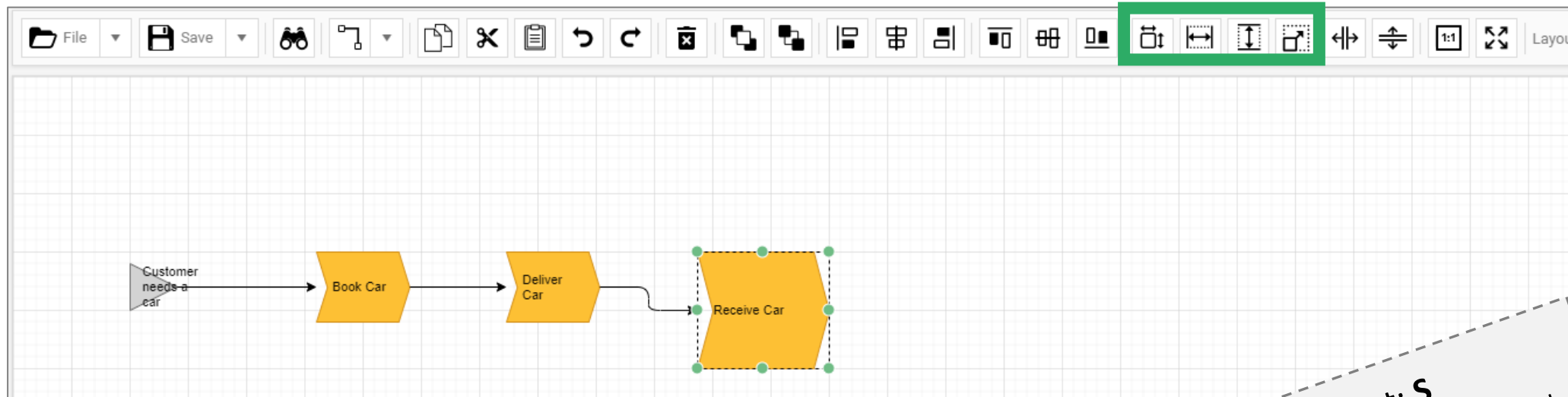

- Then press one or more of the action buttons
 - Resize to original size
 - Align width (with first selected object)
 - Align height (with first selected object)
 - Align size (with first selected object)

Shortcut: S
Copy the Size of the first selected object to all the subsequently selected objects

Alignment

- Use the buttons in the toolbar to align symbols with first selected

- Align left edge
- Align vertical center
- Align right edge
- Align top edge
- Align horizontal center
- Align bottom edge

- Align horizontal spacing with first and last selected
- Align vertical spacing with first and last selected

Shortcut: J
Align the selected objects respective of the first selected object

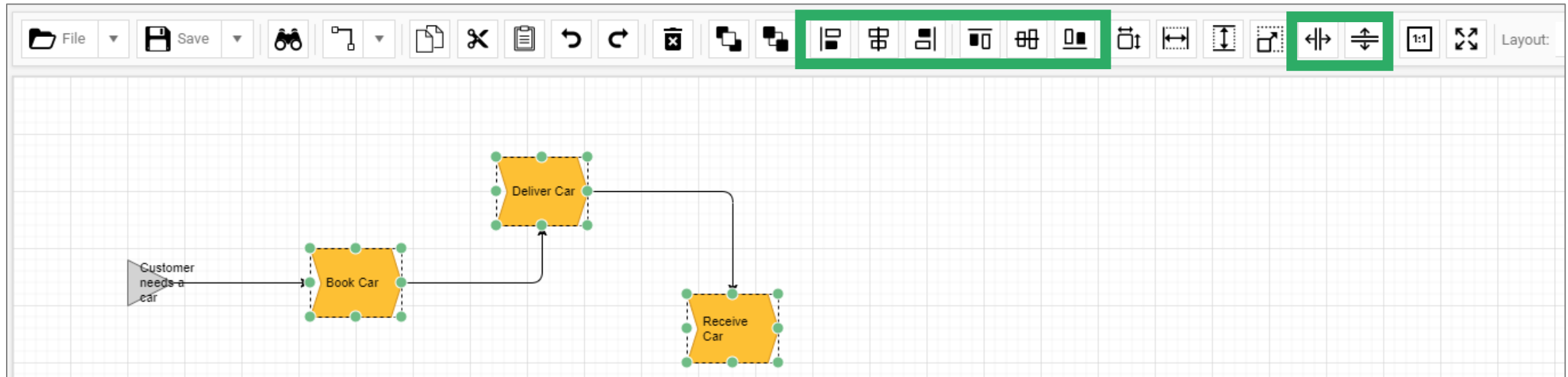

Arrangement

Use the buttons in the toolbar to move symbols to front or back

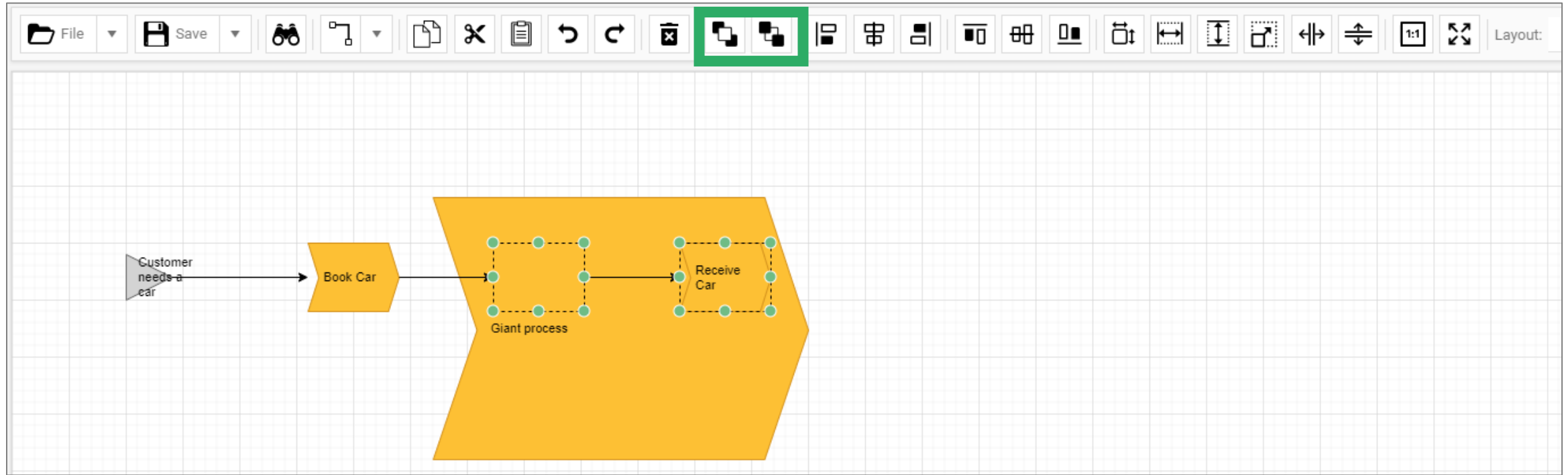

Edit symbol characteristics

The Property window on the right side of the diagram reflects the diagram (or selected symbol)

- 1 Select a symbol to view its properties
- 2 Select the 'Symbol' tab to edit graphics style of the symbol
- 3 Select the 'Label' tab to edit the label style
- 4 Select the 'Attributes' tab to edit/view properties
 - 4a Governance actions
 - 4b Property filter (toggle between favorites properties or full view)

The Symbol tab is selected, showing options for editing the symbol's appearance. The 'Graphic Name' is 'BusinessProcess_S...'. The 'Symbol color' is set to orange. The 'Fill opacity' is 100%. The 'Shadow' is unchecked. The 'Symbol size' is H: 60, W: 80. The 'Border color' is also orange. The 'Border opacity' is 100%. The 'Border width' is 1. The 'Border style' is 'Solid'.

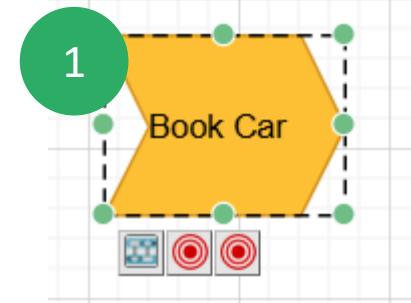

The Label tab is selected, showing options for editing the label's appearance. The 'Label Function' is 'CurrInst->GetBusPrcLabel(CurrGIDMark);'. The 'Label font' is set to a default font. The 'Label size' is 11 px. The 'Label color' is black. The 'Label appearance' is 'Original'. The 'Label style' includes 'Bold', 'Italic', and 'Underline'. The 'Label adjustment' is 'Left'.

The Attribute tab is selected, showing governance actions and property filters. The 'Circulate' button is highlighted. The 'Owner' is 'Chief Operating Officer'. The 'Responsible' is 'Rental manager'. The 'Resources' include 'Peder Witt Scheller', 'Joel Bedore', 'Fredrik Voicemail', and 'Christian Soto'. The 'Consulted' are 'Gitte Biggins' and 'Bo Folino'. The 'Informed' is 'Håkan Fredrik'. The 'Deliver Capability' is 'Car rental service'. The 'Uses information' includes 'Booking type', 'Car', 'Customer', 'Rental contract', 'Booki', 'Booki', 'Accou', 'Agreement', 'Agreement Asset Usage', 'Agreement Item', and 'Beacon'. The 'IT Support' includes 'Booking system', 'Customer system', and 'CCTV System (Closed Circuit TV)'. The 'Uses Functionality' is empty. The 'Confidentiality classification' is empty. The 'Privacy classification' is empty. The 'Positive effect on' is empty. The 'Negative effect on' is empty. The 'Breaks down to' is empty. The 'Visualised by' is 'Book car'. A green box labeled 'Property Window' is overlaid on the right side of the window.

Import - Text to model

1 Select "Import from Text"

2 You can type in/insert text in the "Text to Model" box

*NOTE there is a short guidance text for how to insert text when using the default setting for the **Connection** and **Hierarchical** layout types*

2a

3 The model will be created based upon the "Settings" Here you can choose between different Layout types, to which template(s) the inserted text should be "translated", select Separator and specify symbol size.

4 You can shift between different layouts

Import - Table to model

1

The import from table can be used to easily draw workflow-diagrams

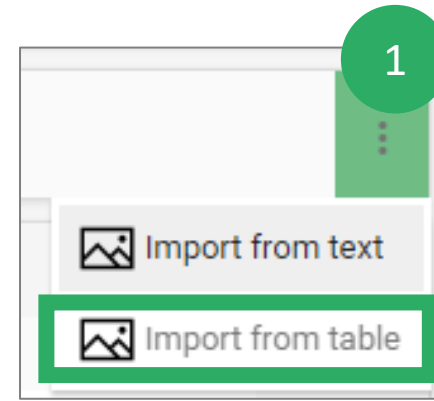

2

Once you type in the columns in the table the model will be created

3

You can select/change symbol template for the symbol

4

When you refer to a symbol in "Connects To" column the symbols will be connected (activities in the same row will be autoconnected)

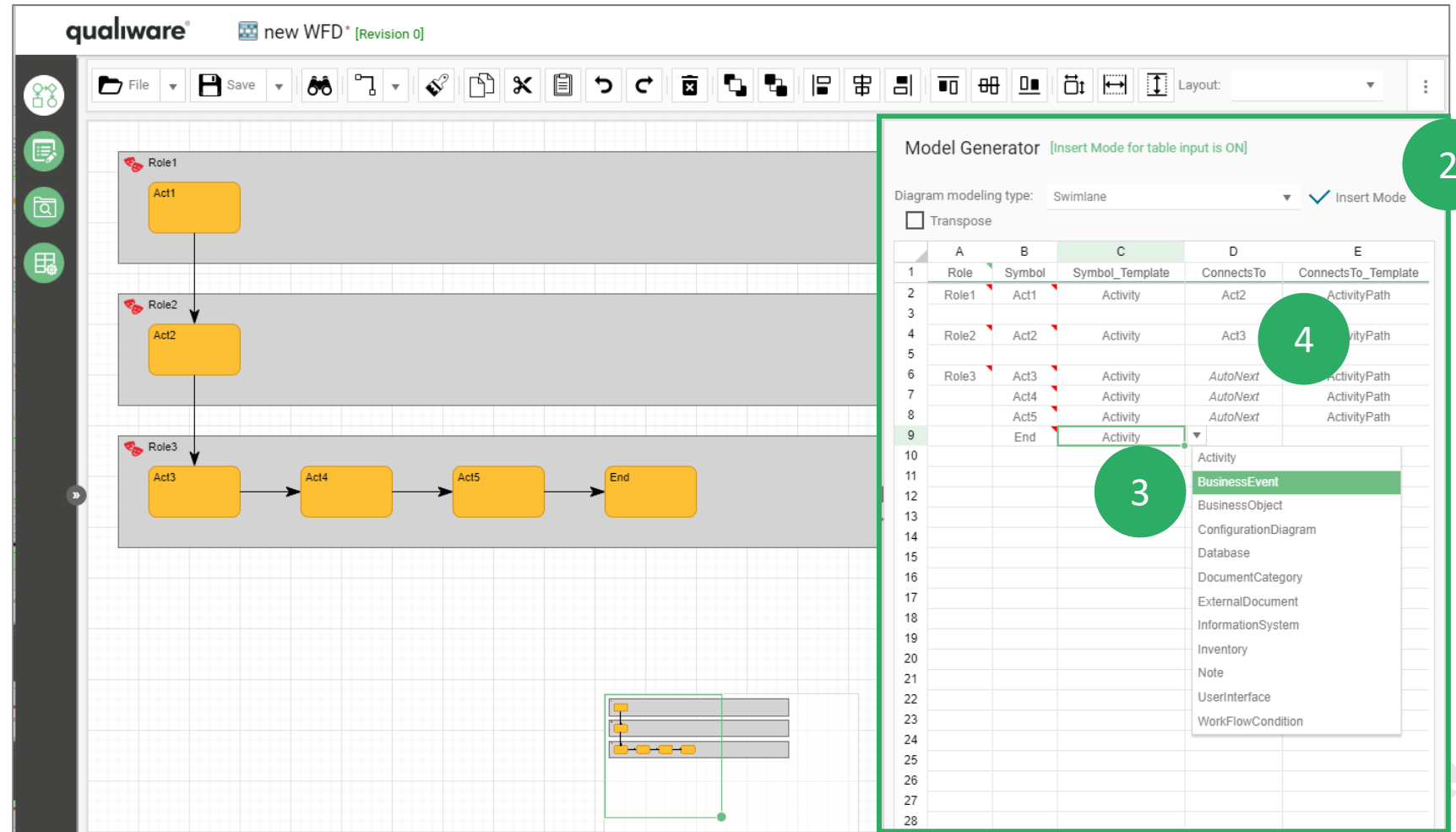

The screenshot shows the Qualware software interface with a workflow diagram on the left and a Model Generator table on the right. The workflow diagram consists of three swimlanes: Role1 with Act1, Role2 with Act2, and Role3 with Act3, Act4, Act5, and End. The Model Generator table is a spreadsheet with columns A through E and rows 1 through 28. The table contains the following data:

	A	B	C	D	E
1	Role	Symbol	Symbol_Template	ConnectsTo	ConnectsTo_Template
2	Role1	Act1	Activity	Act2	ActivityPath
3					
4	Role2	Act2	Activity	Act3	ActivityPath
5					
6	Role3	Act3	Activity	AutoNext	ActivityPath
7		Act4	Activity	AutoNext	ActivityPath
8		Act5	Activity	AutoNext	ActivityPath
9		End	Activity		
10					
11					
12					
13					
14					
15					
16					
17					
18					
19					
20					
21					
22					
23					
24					
25					
26					
27					
28					

The Model Generator table has a dropdown menu open for the 'Activity' template in row 9, column C. The dropdown menu lists various symbol templates: Activity, BusinessEvent, BusinessObject, ConfigurationDiagram, Database, DocumentCategory, ExternalDocument, InformationSystem, Inventory, Note, UserInterface, and WorkflowCondition. A green circle with the number '3' is placed over the dropdown menu. A green circle with the number '4' is placed over the 'ConnectsTo' cell in row 4, column D. A green circle with the number '2' is placed in the top right corner of the Model Generator table area.

Layout

1

You can shift between different layouts

The Web-modeler will automatically organize the objects according to the selected layout

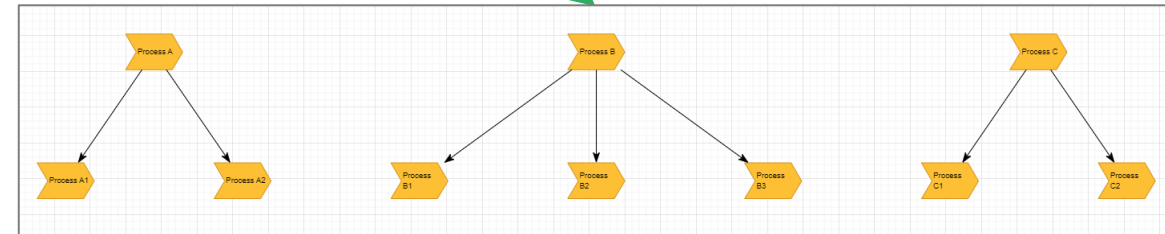
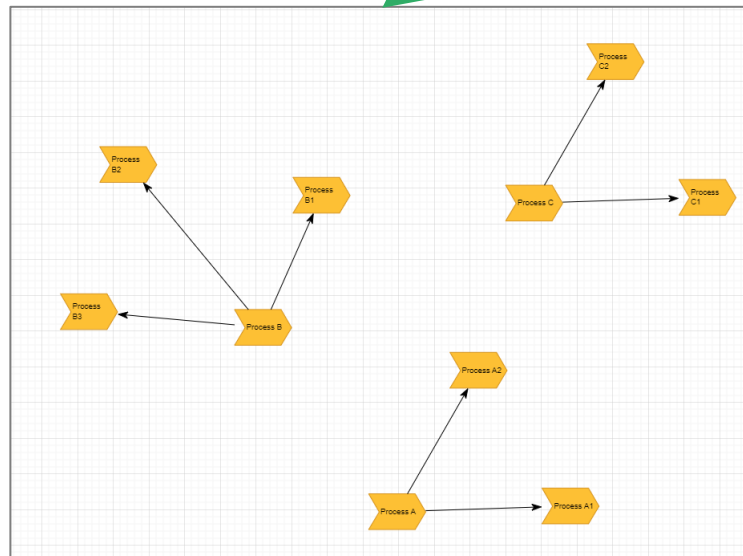
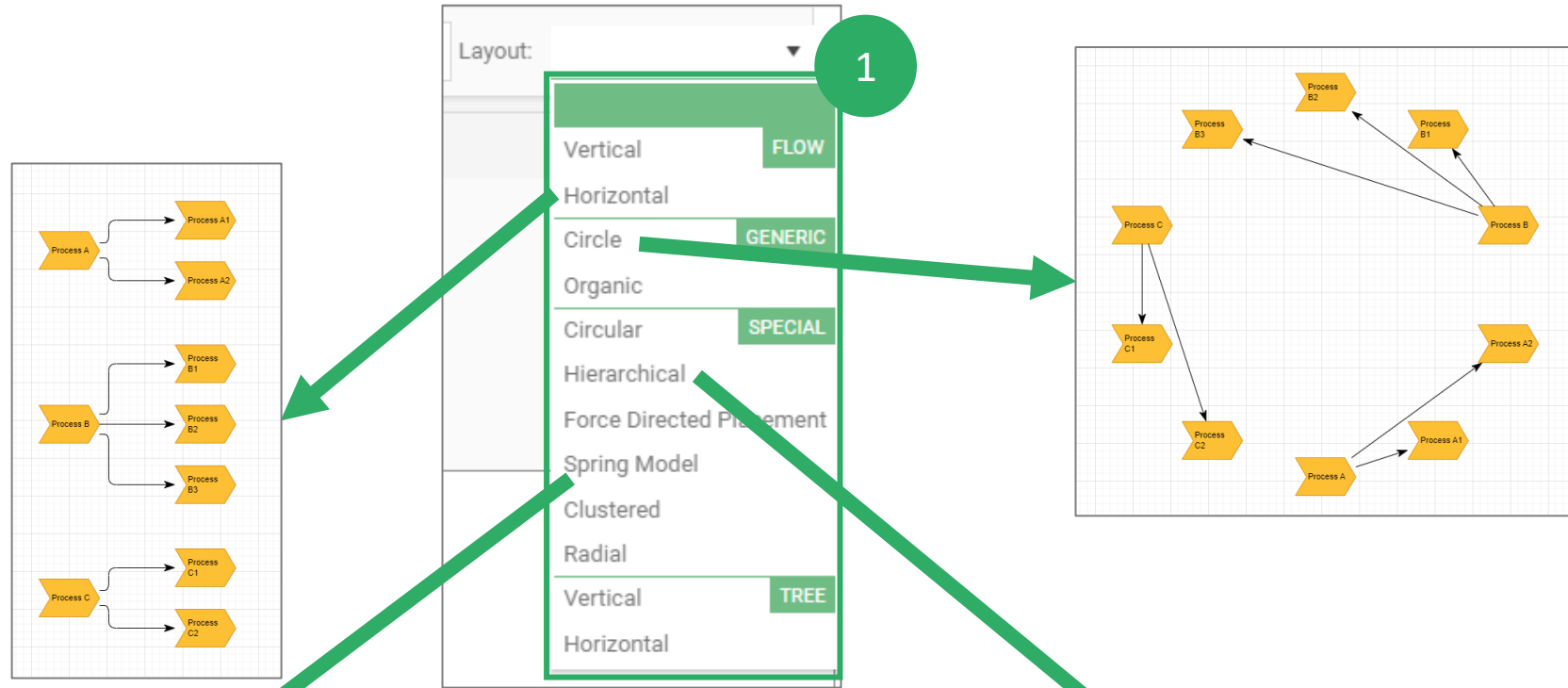

File and Save icons

The **File** menu contains four options:

- Create a New Diagram (10.9)
- Open an existing diagram
- Print version of the diagram
- Revert back to the version of the diagram when it was last saved
- Compare revision (10.9)
- Exit the web-modeler

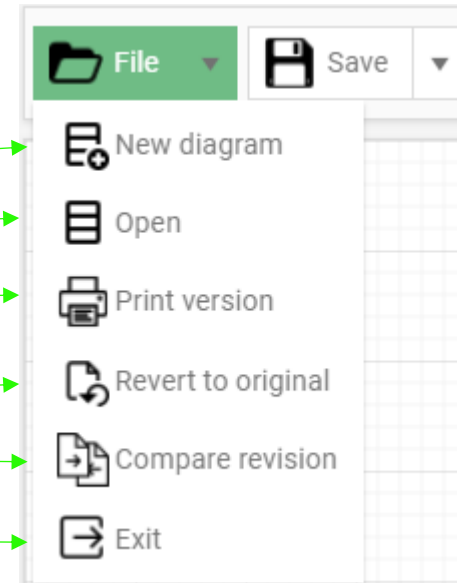

The **Save** menu contains four options:

- Save the diagram to the Repository
- Save the diagram as a file of the type

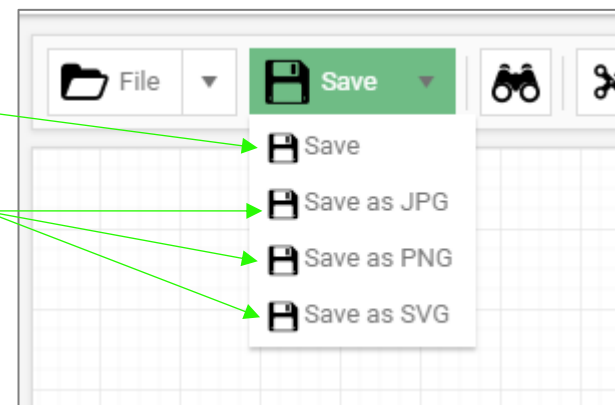

Multi diagram support in web-modeler

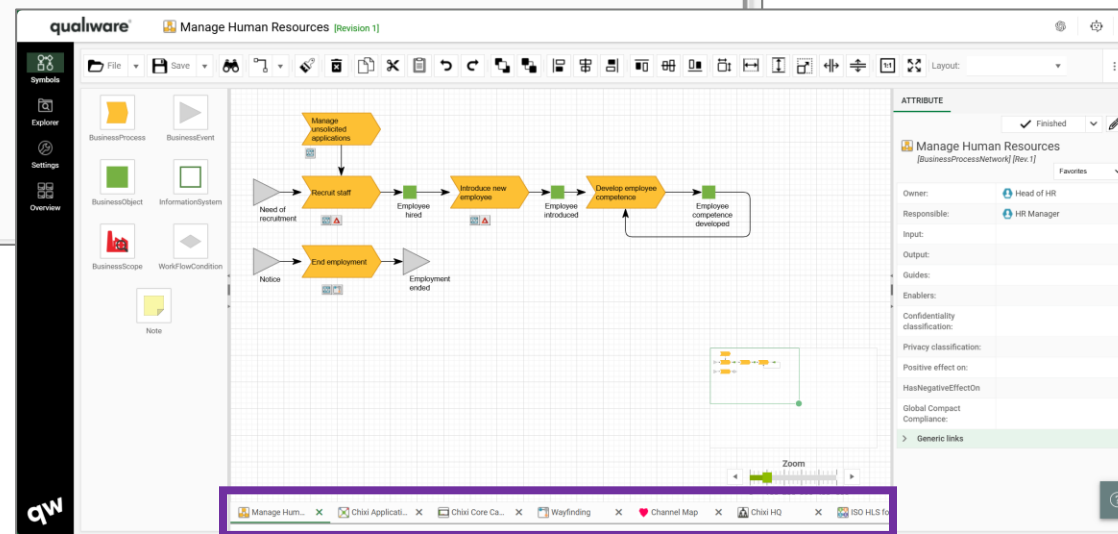
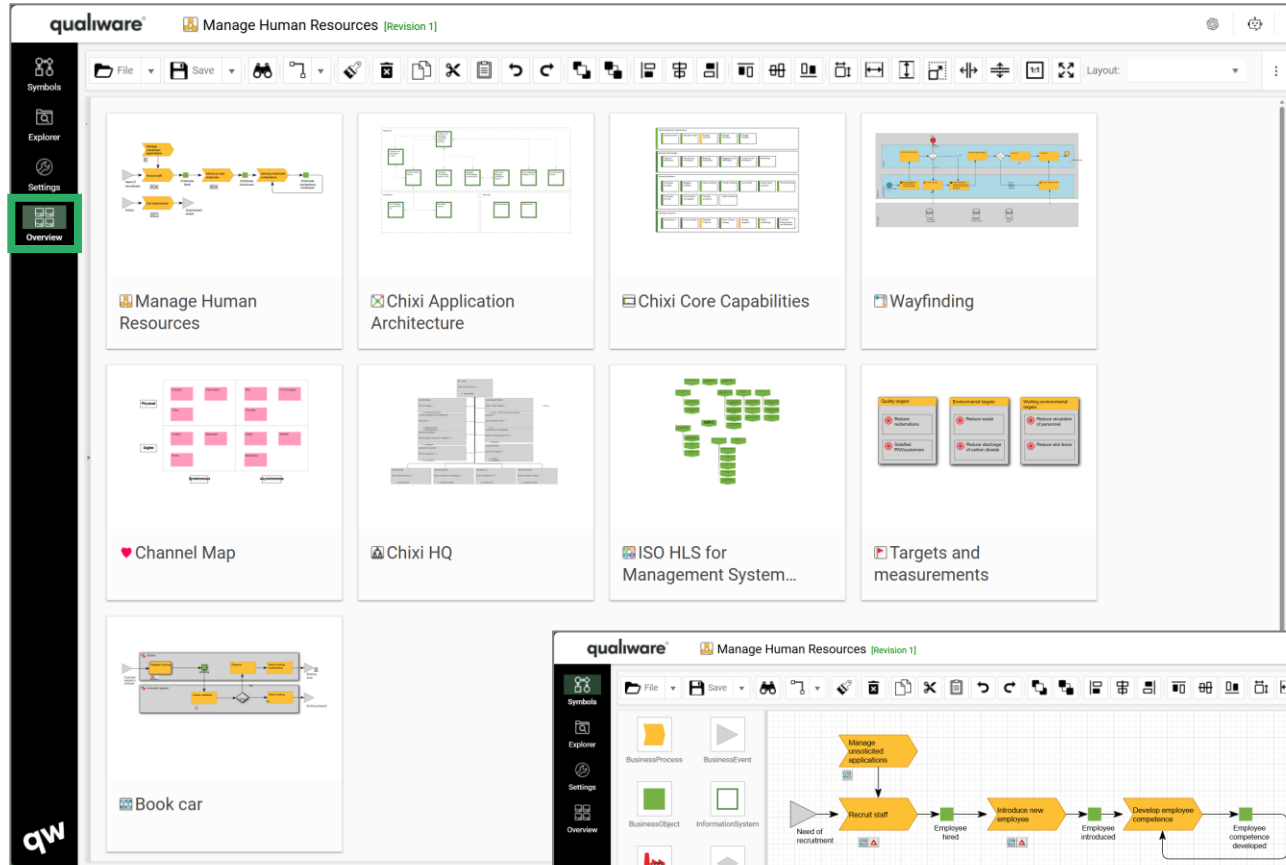

- QualiWare 10.9 introduces multi diagram support in the web-model:
- it is possible to open multiple diagrams in web-modeler
- select “Overview” in the left window to see all open diagrams
- you can select between the diagrams from the tabs in the bottom

Useful shortcuts in Web-modeler

Shortcut	Description
F1	Open Help information pertaining to the selected object
F2	Rename the selected object
F3	Search
J	Align the selected objects respective of the first selected object
S	Copy the Size of the first selected object to all the subsequently selected objects
Spacebar	Automatically re-draw the selected connections
ALT + Left-click	Selecting an object and ALT+ Left-clicking on an object's label opens the label editor
ALT + Left-click + move mouse	ALT+Left-click a label/button panel while moving the mouse, moves the label/button panel
CTRL + A	Select all objects in the diagram
CTRL + F	Find a symbol in the diagram
CTRL + G	Toggle the drawing grid
CTRL + Y	Redo
CTRL + Z	Undo
Arrow-keys	Move the selected object in the arrow key direction
Shift + Z	Automatically zoom to view the entirety of the model
Press and hold Z + Left-click + move mouse	Zoom to the window selected by the mouse
1	Zoom to 100 %
Shift + CTRL + Left-click + move mouse	Create/remove space between objects in the direction of mouse movement. This will move all object(s) to the right and below the mouse click (shown by support lines)



Describe a process

qualiware

Describe a process (edit properties)

3 Use Governance Actions to Edit all properties

View the 'favourite' properties in the **Properties tile.**

1 Toggle the Inline Editing to edit the properties directly

2 Click the pencil to edit the line or click the link to open the dialog to browse the repository for relevant object (or create new)

The screenshot shows the Qualware interface with a process flow diagram on the left and a properties tile on the right. The process flow includes steps: Book Car, Deliver Car, Receive Car, Perform overhaul, and Car returned. The 'Receive Car' step is highlighted with a red box and a green circle '1'. The properties tile for 'Receive Car' is shown below the diagram, with a pencil icon highlighted by a green circle '2'. The top right of the interface has a toolbar with 'Edit', 'Circulate', and a help icon, with a green circle '3' highlighting the 'Edit' button.

The screenshot shows the 'Properties (Receive Car)' dialog box with a list of roles and a 'Responsible...' selection dialog. The 'Responsible...' dialog is open, showing a search bar and a list of roles. A green arrow points from the pencil icon in the 'Responsible...' field of the 'Properties' dialog to the 'Responsible...' dialog.

Name	Template	Last modified	By	Status	Tag
<input type="checkbox"/> Customer Service	Position	2005.04.13 ...	Susanne.F.L...	Development	
<input type="checkbox"/> Customer Service CPH	Position	2018.06.06 ...	Harriet Hans...	Development	
<input type="checkbox"/> Customer service manager Asia	Position	2018.05.22 ...	Harriet Hans...	Development	
<input type="checkbox"/> Customer Service Manager CPH	Position	2021.10.31 ...	Kuno Broder...	Development	
<input type="checkbox"/> Customer service manager UK	Position	2018.05.22 ...	Harriet Hans...	Development	
<input type="checkbox"/> Service Delivery Director	Position	2018.01.31 ...	Edward Han...	Development	
<input type="checkbox"/> Service Delivery Manager	Position	2018.01.31 ...	Harriet Hans...	Development	
<input type="checkbox"/> Service manager	Position	2009.05.07 ...	Albert Ottos...	Development	
<input type="checkbox"/> Service Manager Frankfurt	Position	2018.05.22 ...	Harriet Hans...	Development	

Describe a process (edit properties)

To open the dialog for the object from the web-modeler:

Select the symbol, right-click and click **Edit properties...**

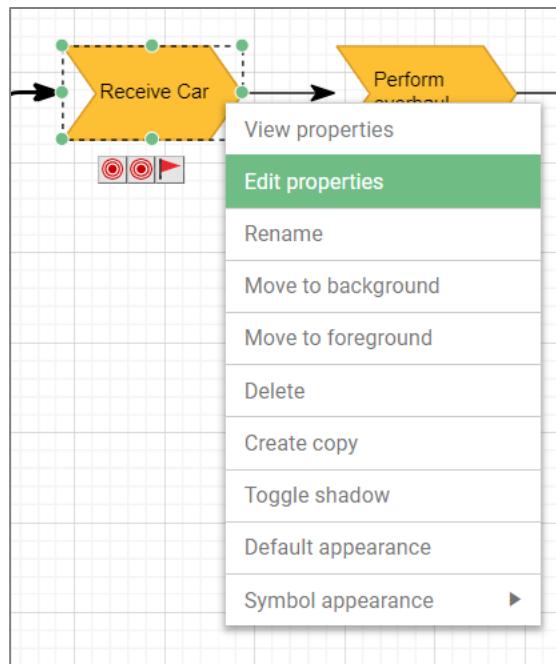

To open the dialog for the object from the web viewing:

Click the symbol to open the info-box and click **Edit**

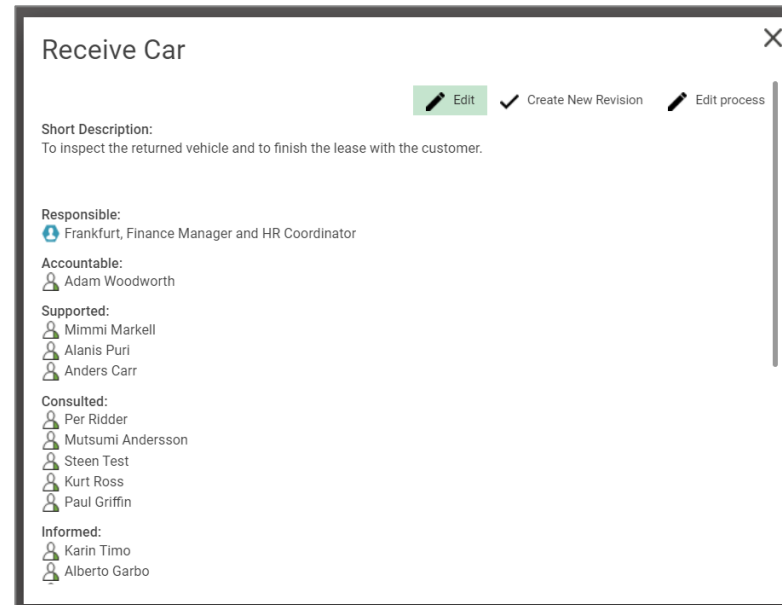

To open the dialog for the object from the Spreadsheet:

- a Update the properties directly in the Spreadsheet cells, or
- b1 Select the cell with the object name and
- b2 click the **Open** button from the symbol bar.

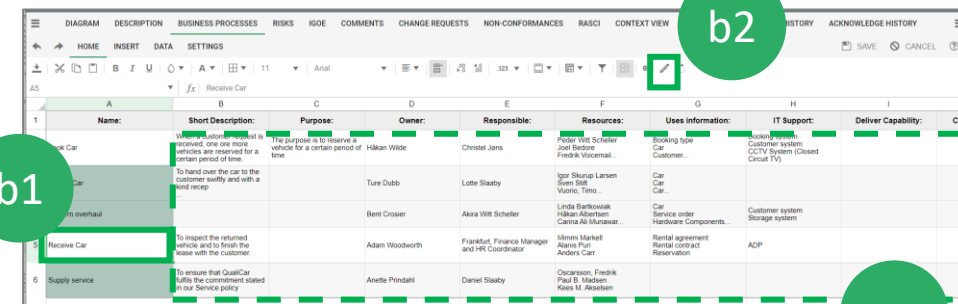

Describe a process

The BusinessProcess Template contains multiple tabs each containing a set of properties.

Receive Car

BusinessProcess

- Consulted
- Decomposition
- Capability
- Start - End
- Input Output
- Guide Enabler
- Information
- IT Support
- ApplicationFunctionality
- > GDPR
- Economy
- Controls
- Influences
- HealthCheck
- ABC
- Describe
- > Associate
- > Governance

Short Description:
To inspect the returned vehicle and to finish the lease with the customer.

Purpose:

Responsible: Kathe Sonnich Thomsen

Owner: Stefan Runfors

Resources:

...	Name	Template
	Mimmi Markell	Person
	Alanis Puri	Person
	Anders Carr	Person

OK CANCEL APPLY

Properties on the *BusinessProcess* "Tab":



Short description
Text field



Purpose Text field



Responsible
Link to a person, role, org.unit,
position



Resources
Link to a person, role, org.unit,
position, resource, business object

Select responsible for a process

Properties for BusinessProcess

Receive Car

BusinessProcess

Short Description:
To inspect the returned vehicle and to finish the lease with the customer.

Purpose:

Responsible: Kathe Sonnich Thomsen

Owner: Stefan Runfors

Resources:

Name	Template
Mimmi Markell	Person
Alanis Puri	Person
Anders Carr	Person

OK CANCEL APPLY

Press the **Link** button to create a link to an object

Select a template
Select existing object or create a new

Select...

Show selected (1)

Name	Template	Last modi...	By	Status	Tag(s)
<input type="checkbox"/> Head of Alloys pre-p...	Position	2013.07...	JacobL		
<input type="checkbox"/> Head of Alloys prod...	Position	2013.07...	JacobL		
<input type="checkbox"/> Head of BE Asia	Position	2018.05...	Harriet Ha...		
<input type="checkbox"/> Head of BE Copenh...	Position	2018.05...	Harriet Ha...		
<input type="checkbox"/> Head of BE Frankfurt	Position	2018.05...	Harriet Ha...		
<input type="checkbox"/> Head of BE UK	Position	2018.05...	Harriet Ha...		
<input type="checkbox"/> Head of Facility Man...	Position	2018.04...	Harriet Ha...		
<input type="checkbox"/> Head of Ground Ope...	Position	2018.04...	Harriet Ha...		
<input checked="" type="checkbox"/> Head of HR	Position	2018.05...	Harriet Ha...		
<input type="checkbox"/> Head of HR Asia	Position	2018.05...	Harriet Ha...		
<input type="checkbox"/> Head of HR Copenh...	Position	2018.05...	Harriet Ha...		
<input type="checkbox"/> Head of HR Frankfurt	Position	2018.05...	Harriet Ha...		

SELECT CANCEL

Relations organization - process

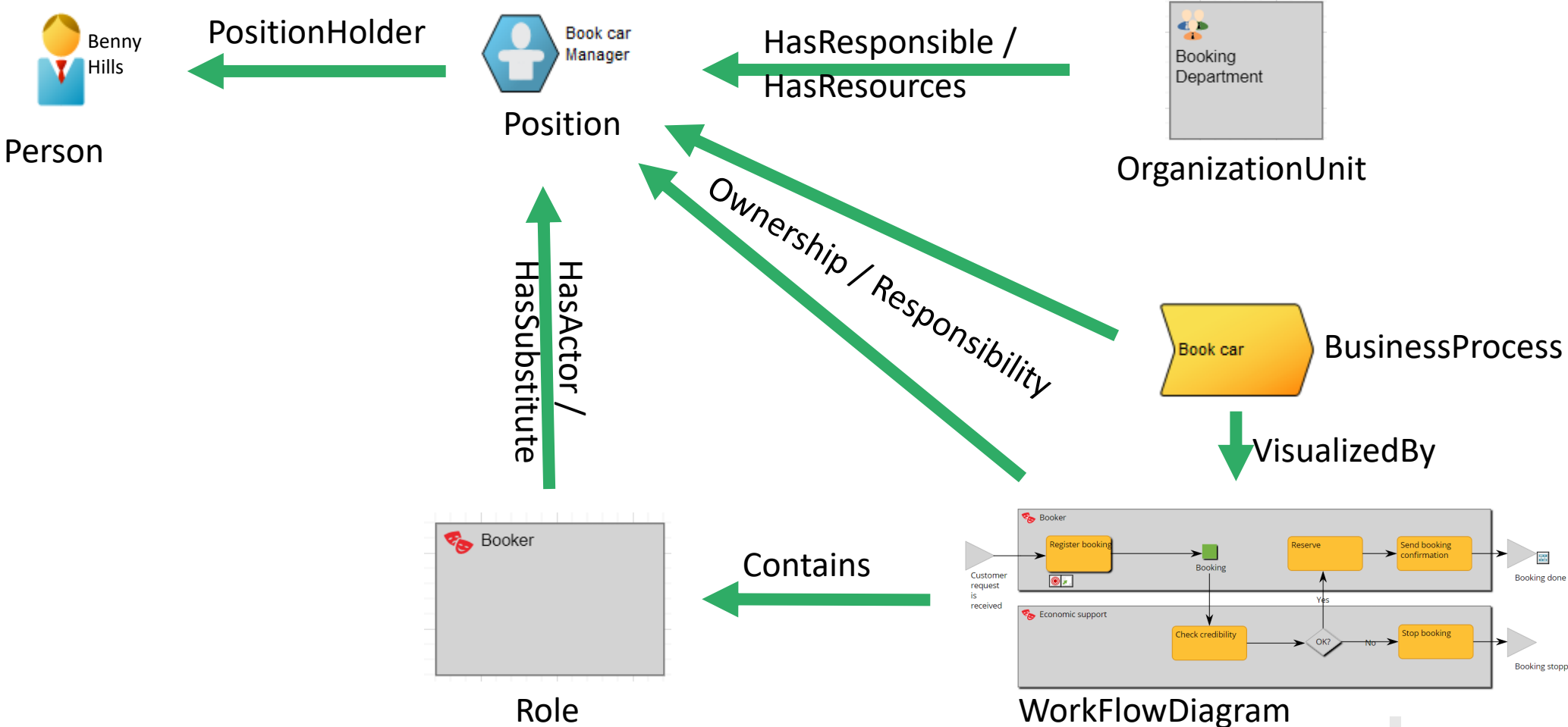

Define resources for a process

Properties for BusinessProcess

BusinessProcess

Short Description:
To inspect the returned vehicle and to finish the lease with the customer.

Purpose:

Responsible: Kathe Sonnich Thomsen

Owner: Stefan Runfors

Resources:

+ CREATE EDIT INSERT REMOVE

Name	Template
Mimmi Markell	Person
Alanis Puri	Person
Anders Carr	Person

OK CANCEL APPLY

Press the **Create** or **Insert** button to create a link to an object

Select a template
Select existing object or create a new

Resources...

Show selected (0)

john

Name	Template	Last modified	By	Status
<input type="checkbox"/> Alice Johnson	Person	2018.02.13 15:42:...	Harriet ...	
<input type="checkbox"/> Jeff Johnson	Person	2018.02.13 15:37:...	Harriet ...	
<input type="checkbox"/> John Andersen	Person	2018.04.26 12:44:...	Harriet ...	
<input type="checkbox"/> John Brodersen	Person	2018.04.26 12:44:...	Harriet ...	
<input type="checkbox"/> John Chakravarty	Person	2018.04.26 12:44:...	Harriet ...	
<input type="checkbox"/> John Churilin	Person	2018.04.26 12:44:...	Harriet ...	
<input type="checkbox"/> John Doe	Person	2022.02.07 15:20:...	Jacob L...	
<input type="checkbox"/> John Domenech Domen...	Person	2018.04.26 12:44:...	Harriet ...	
<input type="checkbox"/> John Foged Schmidt	Person	2018.04.26 12:44:...	Harriet ...	
<input type="checkbox"/> John Gotze	Person	2018.04.26 12:44:...	Harriet ...	
<input type="checkbox"/> John Govindan	Person	2018.04.26 12:44:...	Harriet ...	
<input type="checkbox"/> John Hørlyk	Person	2018.04.26 12:44:...	Harriet ...	

SELECT CANCEL

Relations between objects

The screenshot shows the 'Receive Car' application interface. On the left is a navigation menu with 'BusinessProcess' highlighted. The main area displays the 'BusinessProcess' details, including a 'Short Description' and a 'Resources' table. The 'Resources' table has a toolbar with 'CREATE', 'EDIT', 'INSERT', and 'REMOVE' buttons, and a list of resources with 'Name' and 'Template' columns. The resource 'Alanis Puri' is selected and highlighted in green. At the bottom are 'OK', 'CANCEL', and 'APPLY' buttons.

Name	Template
Mimmi Markell	Person
Alanis Puri	Person
Anders Carr	Person

Properties for BusinessProcess

To access (open) a reference:

- Click the **Edit** button

To delete the link to an object:

- Select and press DELETE (listviews)

Change the sequence of objects in a listview:

- Select and click the up/down buttons to move the selected object to the desired position

BusinessProcessNetwork

ATTRIBUTE

Market product and service

Template: BusinessProcessNetwork
Revision: 0

Description:
N/A

Responsible:
Bill Johansson

Owner:
Aase Motor

Click the empty space in the diagram (in the Web-Modeler) and press the **Edit** button to open the dialog for the diagram

Edit Edit Diagram Finished

...or Click the **Edit** button on the diagram actions on the web to open the dialog for the diagram

Market product and service

BusinessProcessNetwork

- > Associate
- > Governance

Description:

Owner: Aase Motor

Responsible: Bill Johansson

OK CANCEL APPLY

Expanded text editor

All multiline fields can expand to a full-screen text editor.

To expand a text field: Press **F8** or click the **Expand** button

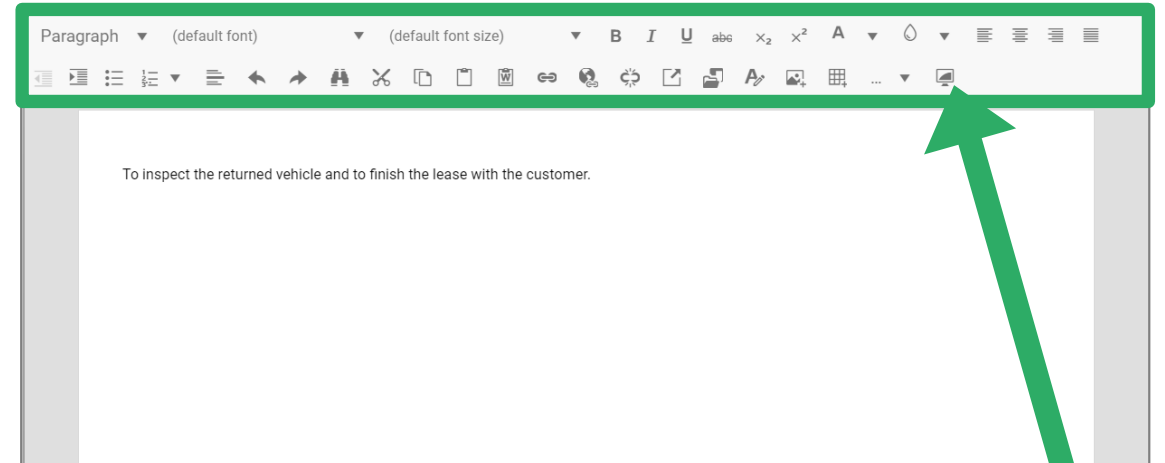
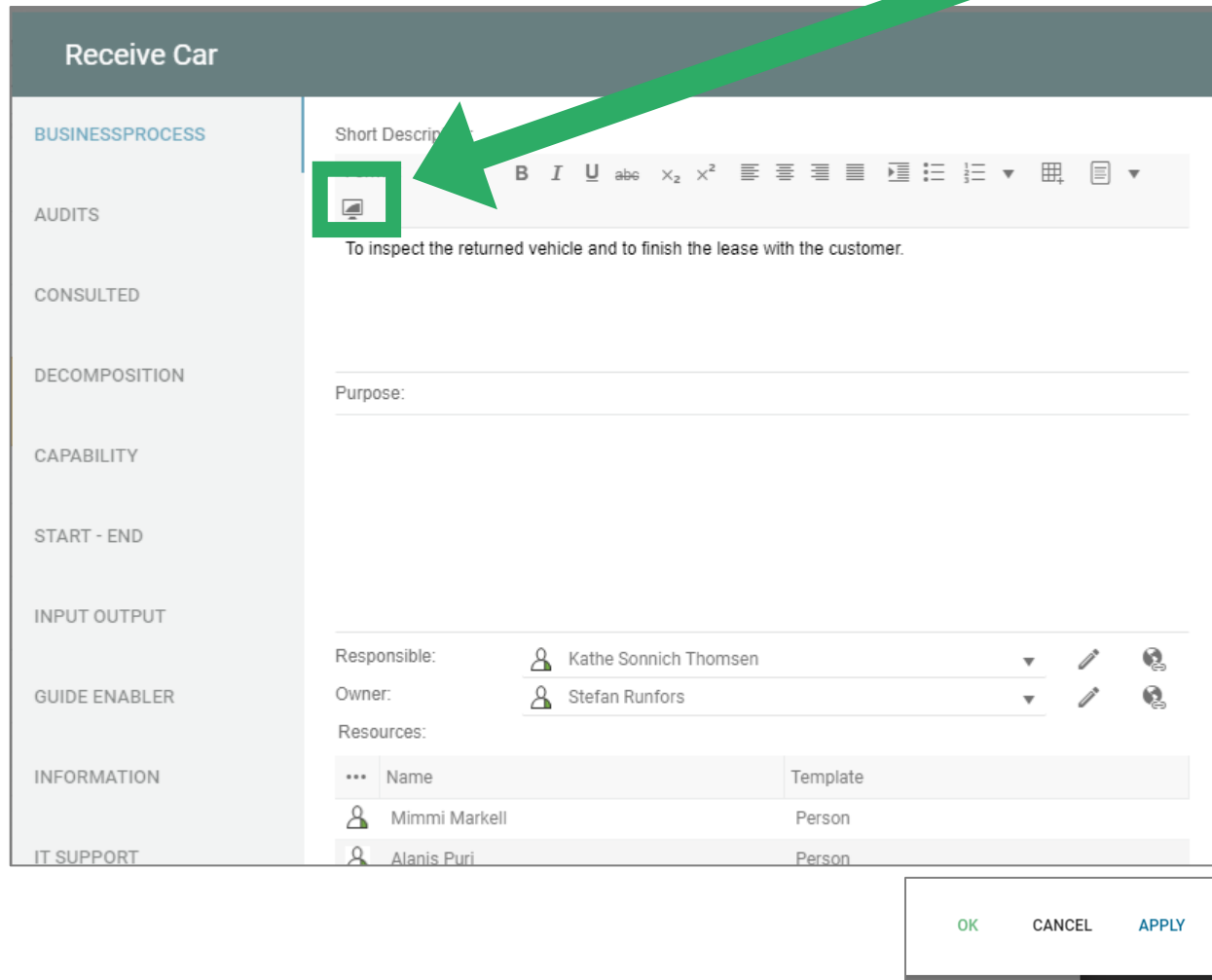

Toggle back from full-screen by clicking the same button.
All changes made in full screen mode will be placed in the
Multiline field.

Nothing is saved until OK or Apply button is pressed !

Describe a process using a spreadsheet

Properties of each of the Processes on a diagram can easily be described/ modified using the Spreadsheet view.

a Click the tab “**Business Processes**” to switch to the spreadsheet representation (Classic Layout)

b ..or use the **BusinessProcess properties** from the Analyzing and Improving Dashboards / Edit tile

It is possible to edit the objects directly from the spreadsheet in each of the property columns.

Any changes made will be highlighted in **bold + italic** and will only be applied to the objects once the “**Save**” button is clicked.

See more about Spreadsheets later in this introduction

Layout: Analyzing and Improving

Edit

b

BusinessProcess properties

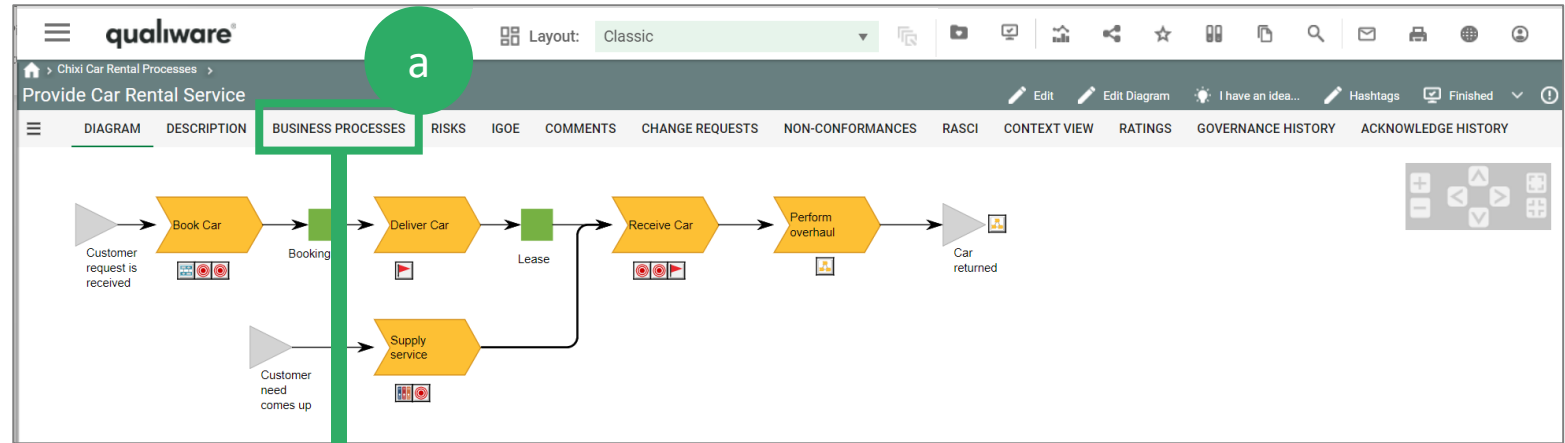















	A	B	C	D	E	F	G	H	I
	Name:	Short Description:	Purpose:	Owner:	Responsible:	Resources:	Uses information:	IT Support:	Deliver Capability:
1	Book Car	When a customer request is received, one or more vehicles are reserved for a certain period of time.	The purpose is to reserve a vehicle for a certain period of time	Håkan Wilde	Christel Jons	Peder Witt Scheller Joel Bedore Fredrik Voicemail...	Booking type Car Customer...	Booking system Customer system CCTV System (Closed Circuit TV)	
2	Deliver Car	To hand over the car to the customer swiftly and with a kind recep...		Ture Dubb	Lotte Slaaby	Igor Skurup Larsen Sven Stift Vuoro, Timo...	Car Car Car...		
3	Perform overhaul			Bent Crosier	Akira Witt Scheller	Linda Barkowiak Håkan Albertsen Carina Ali Munawar...	Car Service order Hardware Components...	Customer system Storage system	
4	Receive Car	To inspect the returned vehicle and to finish the lease with the customer.	<i>This purpose text has been changed</i>	Adam Woodworth	Frankfurt, Finance Manager and HR Coordinator	Ami Markell Puri Carr	Rental agreement Rental contract Reservation	ADP	
5	Supply service	To ensure that QualiCar fulfils the commitment stated in our Service policy		Anette Prindahl	Daniel Slaaby	Oscarsson, Fredrik Paul B. Madsen Kees M. Akseisen			

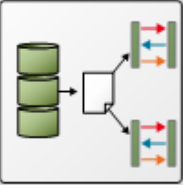
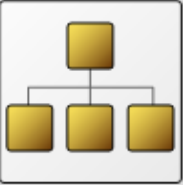

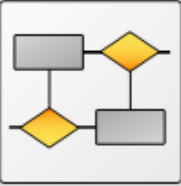
Create Decomposition

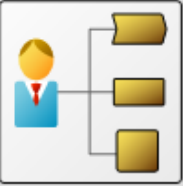
Different levels of diagrams

	Strategy	Process	Application	Information	Organization	Technology
Conceptual	 <p>Strategy</p>	 <p>Business Process Model</p>	 <p>Application Architecture</p>	 <p>Semantic Model</p>	 <p>Stakeholder Model</p>	 <p>Strategic Technology Model</p>
Logical	 <p>Policies</p>	 <p>Business Process Design</p>	 <p>System Design</p>	 <p>Logical Data Model</p>	 <p>Organization Model</p>	 <p>Business Technology</p>
Operational	 <p>Business Rules</p>	 <p>Work Flow</p>	 <p>Component Model</p>	 <p>Physical Data Model</p>	 <p>Human Resource Model</p>	 <p>Physical Technology</p>

Different levels of diagrams can be modelled in QualiWare.

A high-level model can be decomposed to more detailed lower-level models.

Processes

Process



Business Process Model



Business Process Design



Work Flow

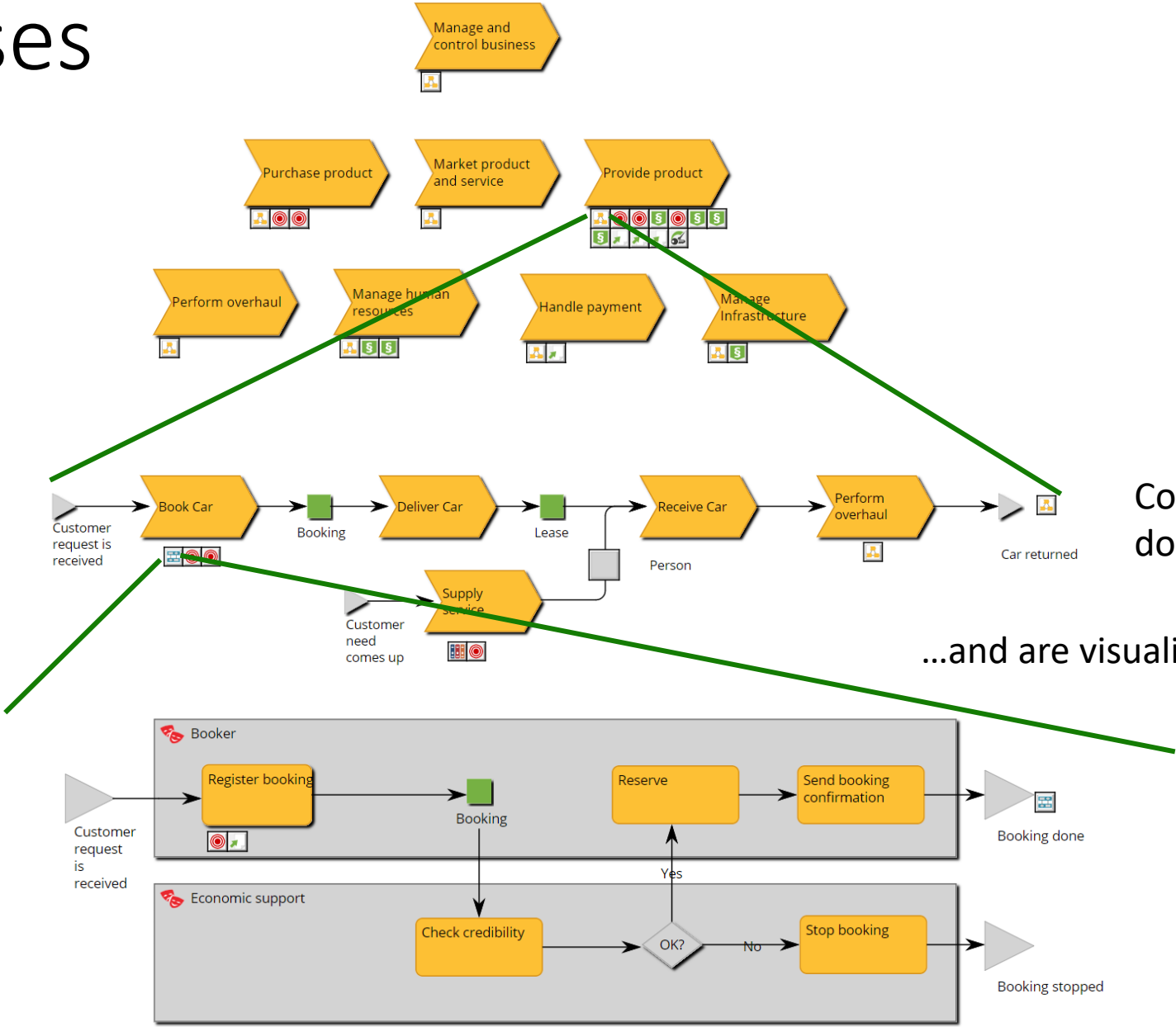

Process hierarchy

- Process Structure
 - Chixi Car Rental Processes
 - Perform overhaul
 - Market product and service
 - Purchase car
 - Provide Car Rental Service
 - Book car**
 - Perform overhaul
 - Manage and control the business
 - Manage human resources
 - Handle payment
 - Manage infrastructure

Core processes break down to sub processes...

...and are visualized by workflow diagrams

Decompose a process

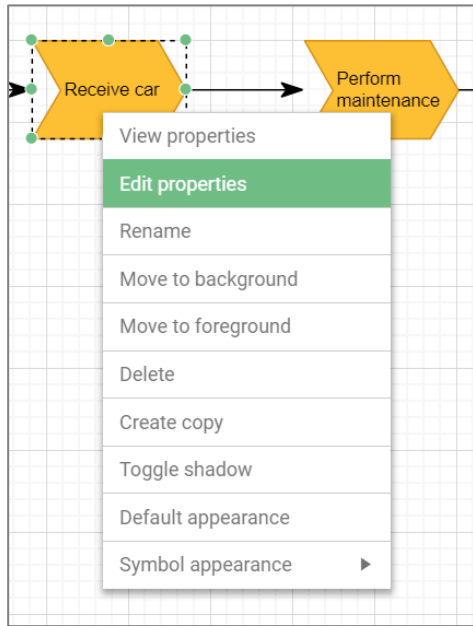

From the **Decomposition** tab a BusinessProcess can be:

- Broken down to a more detailed BusinessProcessNetwork and/or
- Detailed in a BusinessDiagram
- Visualized by a WorkFlowDiagram or BusinessProcessDiagram

The screenshot shows the 'Receive Car' BusinessProcess editor. The 'Decomposition' tab is selected and highlighted in green. The interface includes a left sidebar with various categories like 'BusinessProcess', 'Capability', 'Start - End', etc. The main area shows 'Breaks down to:' and 'Visualized by Work Flow Diagram:' sections, both currently displaying 'No items to display'. A green arrow points from the 'Decomposition' tab to the 'Select...' dialog.

The 'Select...' dialog shows a list of templates under the 'BusinessProcessNetwork' category. The table has columns for Name, Template, Last mod..., By, Status, and Tag(s).

Name	Template	Last mod...	By	Status	Tag(s)
<input type="checkbox"/> Audit Proce...	Busines...	2018.05...	Harriet ...	Develop...	
<input type="checkbox"/> Bag-drop	Busines...	2018.06...	Harriet ...	Approved	
<input type="checkbox"/> Baggage cla...	Busines...	2020.11...	Kuno Br...	Develop...	
<input type="checkbox"/> BMS forside	Busines...	2022.02...	Hege A...	Develop...	
<input type="checkbox"/> CFIA	Busines...	2022.01...	Leighto...	Develop...	
<input type="checkbox"/> Chixi Car Re...	Busines...	2022.04...	Alexand...	Circulati...	
<input type="checkbox"/> Chixi Financ...	Busines...	2018.05...	Harriet ...	Develop...	
<input type="checkbox"/> Chixi Mega ...	Busines...	2019.10...	Kuno Br...	Develop...	
<input type="checkbox"/> Chixi Passe...	Busines...	2021.08...	Kevin O...	Develop...	
<input type="checkbox"/> Chixi Proce...	Busines...	2021.12...	Terje H...	Approved	
<input type="checkbox"/> Control of R...	Busines...	2018.05...	Harriet ...	Develop...	
<input type="checkbox"/> Create Awar...	Busines...	2018.05...	Harriet ...	Develop...	
<input type="checkbox"/> Create Cust...	Busines...	2018.05...	Harriet ...	Develop...	

The 'Select...' dialog shows a list of templates under the 'BusinessDiagram' category. The table has columns for Name, Template, Last mod..., By, Status, and Tag(s).

Name	Template	Last mod...	By	Status	Tag(s)
<input type="checkbox"/> Test	Busines...	2020.12...	Kuno Br...		
<input type="checkbox"/> Test av und...	Busines...	2022.02...	Hege A...		

The 'Select...' dialog shows a list of templates under the 'WorkFlowDiagram' category. The table has columns for Name, Template, Last mod..., By, Status, and Tag(s).

Name	Template	Last mod...	By	Status	Tag(s)
<input type="checkbox"/> Achieve Agr...	WorkFlo...	2022.03...	Leighto...	Develop...	
<input type="checkbox"/> Approve ECR	WorkFlo...	2018.03...	Harriet ...	Finished	
<input type="checkbox"/> Approve Pur...	WorkFlo...	2018.03...	Harriet ...	Develop...	
<input type="checkbox"/> Assess Sup...	WorkFlo...	2020.12...	Kuno Br...	Develop...	
<input type="checkbox"/> Book car	WorkFlo...	2022.01...	Silje Ad...	Approved	
<input type="checkbox"/> Check invoice	WorkFlo...	2018.03...	Harriet ...	Develop...	
<input type="checkbox"/> Communica...	WorkFlo...	2018.05...	Harriet ...	Develop...	
<input type="checkbox"/> Conduct Int...	WorkFlo...	2018.03...	Harriet ...	Develop...	
<input type="checkbox"/> Confirm pur...	WorkFlo...	2022.01...	Andrea...	Develop...	
<input type="checkbox"/> Confirm the ...	WorkFlo...	2021.12...	Terje H...	Develop...	
<input type="checkbox"/> Create and ...	WorkFlo...	2020.04...	Kuno Br...	Develop...	
<input checked="" type="checkbox"/> Create and ...	WorkFlo...	2018.05...	Harriet ...	Develop...	
<input type="checkbox"/> Create Mast...	WorkFlo...	2018.03...	Harriet ...	Develop...	



Workflows

qualiware

Workflow

The diagram **WorkFlowDiagram** is used for describing activities

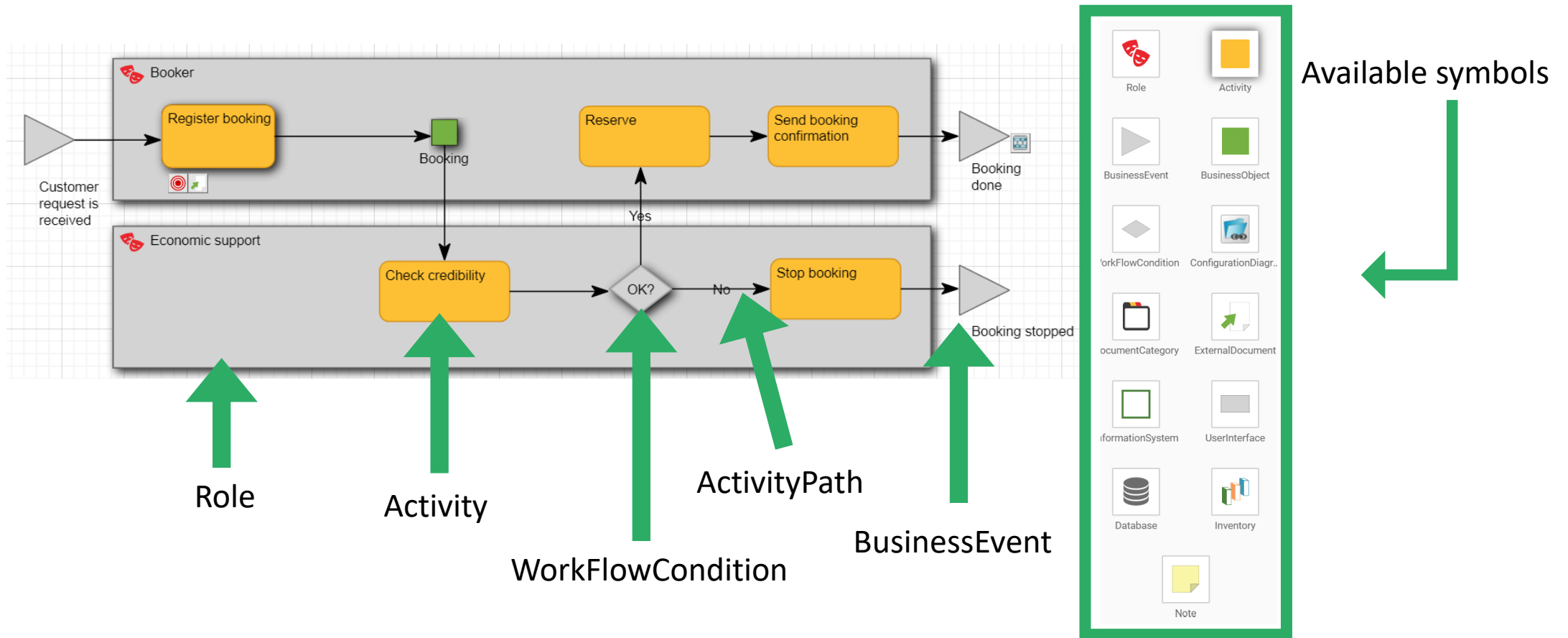

Activity

Properties for Activity – Activity Tab

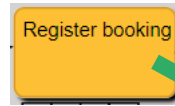

Register booking Edit Create New Revision Edit process

Short Description: The booking is registered together with customer data.

Description: The seller presents the product and service range and in dialogue with the customer decides a appropriate choice. Thereafter the seller ask for the customer's name, social security number, and how the customer wants to pay. All data is recorded.

Register booking

Activity

- Consulted
- Capability
- Start - End
- Input Output
- Information
- IT Support
- ApplicationFunctionality
- > Risk
- > GDPR
- Simulation
- > BPMN
- > UML
- ABC
- Economy
- HealthCheck
- Describe
- > Associate
- > Governance

Short Description: The booking is registered together with customer data.

Breaks Down To:

Name	Template
No items to display	

Responsible: Usman Ali Munawar

Owner: Gary Keyes

Resources:

Name	Template
Carl Soto	Person
Lennart Congressi	Person
Joachim Smith Larsen	Person
Ahola, Olsen	Person
Eugene Soboleva	Person

OK CANCEL APPLY



Short description



Breaks down to - Links to WorkflowDiagram, etc



Responsible and Owner



Resources - Links to Person, Position etc.

Role



Properties for Role – Role Tab

Purchaser

Role

Describe

> Associate

> Governance

Minimum Comp.

Short Description:
Purchaser, which requests that a new vendor be created or a vendor's details should be changed.

Actors:

...	Name	Template	<input type="checkbox"/> Show
	Purchaser	Position	

Substitute:

...	Name	Template
No items to display		

Breaks down to:

...	Name	Template
No items to display		

Super- role:

OK CANCEL APPLY

Purchaser Edit Create New Revision

Short Description: Purchaser, which requests that a new vendor be created or a vendor's details should be changed.

Description:

Last Modified date: 2005 04 11

Last modified by: Kristian-K.Willumsen

Links: Purchaser

Linked by:

Contained in: Create New Vendor Process

- ← Short description
- ← Actors - Links to Person, Position etc.
- ← Substitute – Links to e.g. other roles or IT-systems
- ← Sub roles - Links to other roles
- ← Super role - Links to BusinessFunction

WorkFlowDiagram

Properties for WorkFlowDiagram – **WorkFlowDiagram** Tab

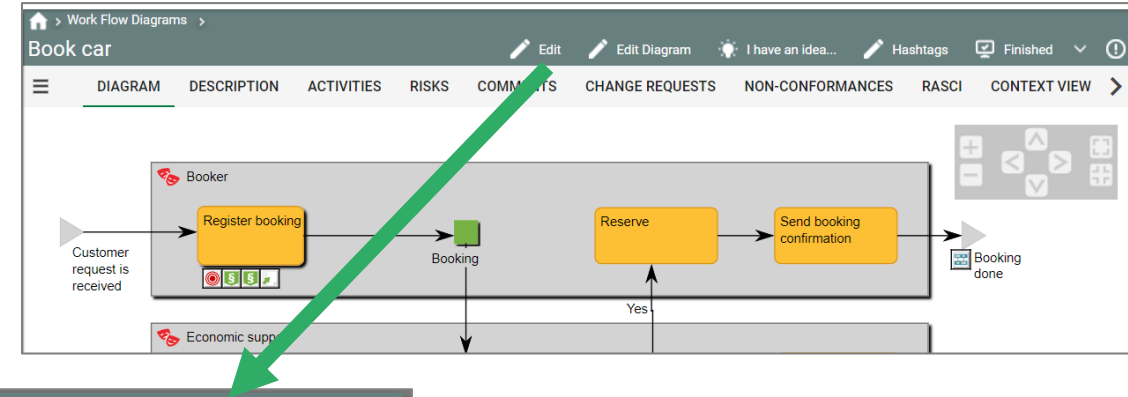

Book car

WorkFlowDiagram

Describe

> Associate

> Governance

Total cost: 0 Cost unit: dkk

Total Duration: 0 Time unit: Day

Standard deviation: 0

Owner: [dropdown]

Responsible: Terje Haugland [dropdown]

Process receiver:

...	Name	Template
No items to display		

Model type: As-Is

OK CANCEL APPLY

- Workflow information
- Owner and Responsible
- Technical Field
- As-is or To-be architecture

Condition



Properties for **WorkflowCondition**

OK?

WorkflowCondition

- Describe
- > Associate
- > Governance

Short Description:
Is the credibility ok?

Show ShortDescription

OK CANCEL APPLY

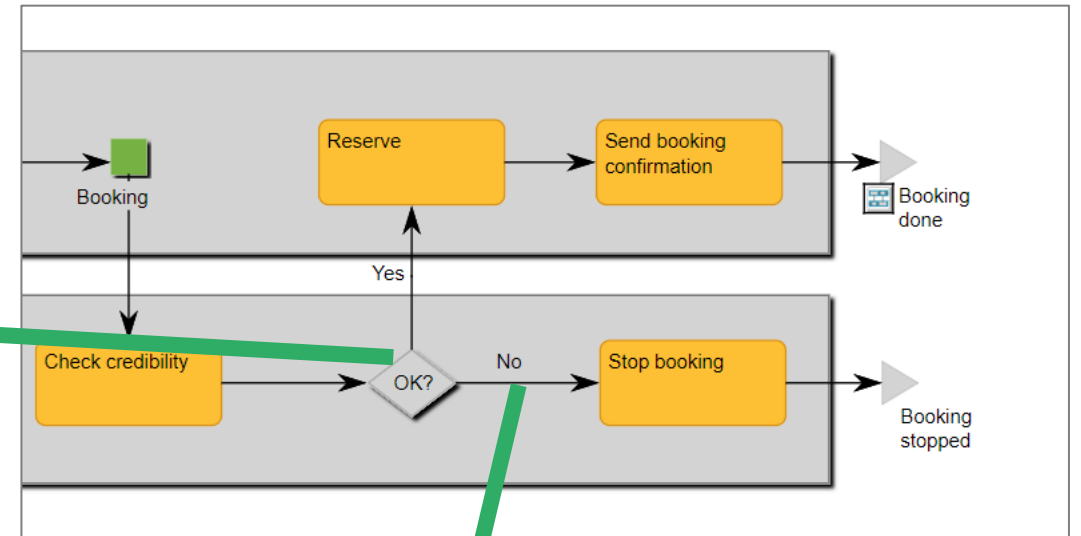

Properties for **ActivityPath**

OK?/Stop booking

ActivityPath

- Data Processing Agreements
- HealthCheck
- Describe
- > Associate
- > Governance

Short Description: Show

Path type: Finish-Start

Gap: _____ Time unit: Day

Overlap: _____

Path probability (%): 100

Path condition: No Show

Business objects:

Name	Template
No items to display	

OK CANCEL APPLY

WorkflowConditions is used to model paths in workflows.

The label on the Activity path can be described in the Short Description and/or in selected in the drop-down in the "Path condition".

Toggle the **Show** box for the relevant fields to select what should be shown on the label on the diagram.

Linking via BusinessEvents



BusinessEvents are used to model Events. A process or workflow can be triggered by one or more BusinessEvent(s), and a BusinessEvent can be an output/result of a process/activity.

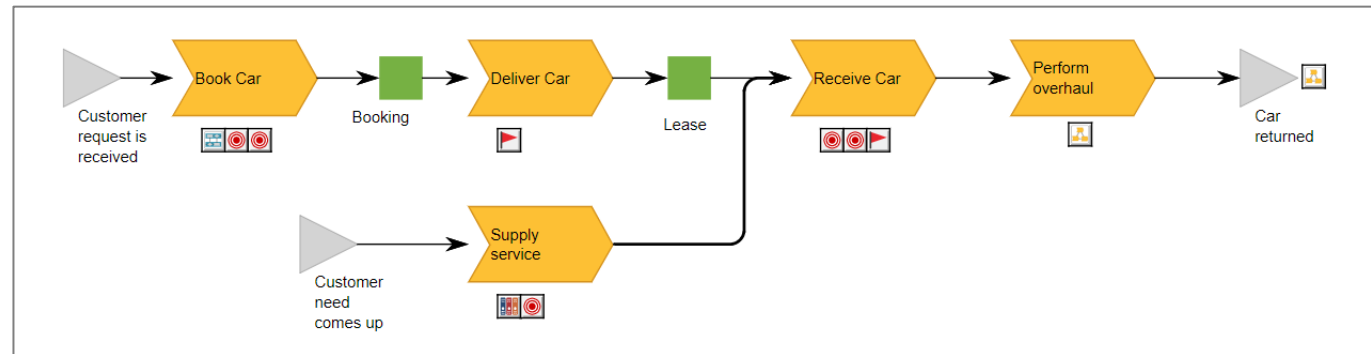

When the same BusinessEvent is reused as output in one process and input in another, the events get linked together, and it is possible to “browse” through the process via the BusinessEvents

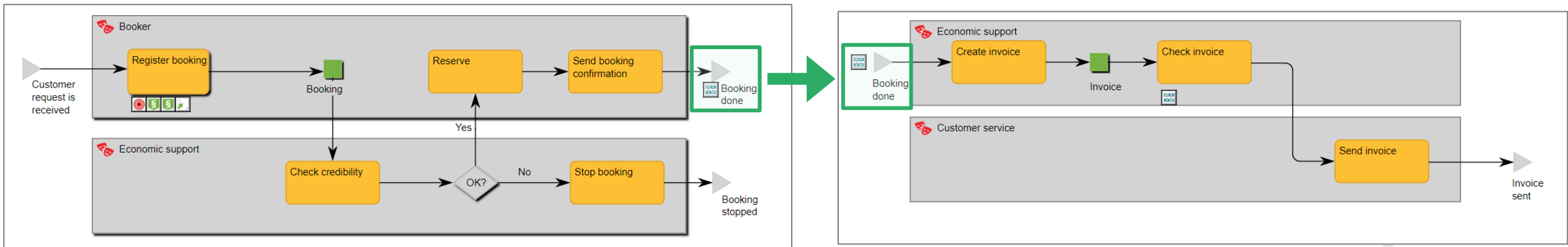

A pair of black-rimmed glasses is positioned horizontally across the center of the image, resting on a stack of papers. The papers are slightly out of focus, showing some text in a non-English language. A semi-transparent green horizontal band is overlaid across the middle of the image, containing the text "External documents and web navigation" in white. The overall lighting is soft and natural, suggesting an indoor setting like a desk or office.

External documents and web navigation

qualiware

Associate tabs

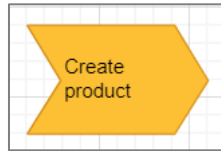

Properties for **BusinessProcess**

The available property-tabs for the different template types are defined by the underlying meta-model.

In addition, all objects have the “**Associate**” tab where the object can be linked to other references such as:

- Strategy (e.g. Visions, Policies, Strategymodels)
- Target (Goals and objectives)
- Performance (KPI and performance diagrams)
- Compliance (Regulations, Rules, Policies and Requirements)
- Documents (ExternalDocument, which are stored outside the repository)
- InherentRisk
- UN (United Nations SDG and policies)
- Other (links to all other object types)

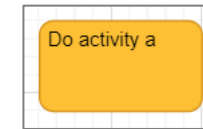

Properties for **Activity**

References to documents



New External Document

External Document
Revision Management
Extended responsibility

Name: *

Document type:

File details

Storage system:

File:

File name:

Responsibility

Responsible:

Owner:

Document details

Short description:

Document number:

Version:

Archive:

Keywords:

OK CANCEL APPLY

Properties for ExternalDocument

- Give the external document a name
- Select **Storage system**

- 1 File System
- 3 HTTP based document server
- 5 QIS based QDM

1 File System (used for files on a shared drive)

File details

Storage system: 1 File System

File:

File name: \\CompanyDrive\Document.pdf

3 HTTP based document server (Used for URLs)

File details

Storage system: 3 HTTP based document server

File:

File name: http://www.qualiware.com

5 QIS based QDM (used to upload files to QualiWare)

File details

Storage system: 5 QIS based QDM

File: Test.docx

File name:

You can link to a Word-document, Excel spreadsheet, pdf-file, URL etc.



Document Management

There is a Standard Desktop for Document Management

DOCUMENT MANAGEMENT

A documents list can be found via the left-menu

The left navigation menu is displayed with the following categories and items:

- High level processes/Value Streams
- Work processes
 - Work Flow Diagram
 - Business Process Diagram (BPMN)
 - BPN, WFD, BPD - GRC
 - Work Process Completion
- Processes - Compliance
- Processes - Roles
- Documents** (highlighted in green)
- Decision Models
- Process analysis
- ArchiMate Process Viewpoints

The dashboard includes several widgets:

- Latest Changes:** A table showing 5 document changes with columns for Name and Last modified.
- Getting Started:** A panel with buttons for 'Create Document', 'Edit Documents', and 'Document Management'.
- Quick Search:** A search interface with fields for Name, Responsible, and Owner.
- Documents Report:** A pie chart and a table showing document status distribution (Approved, Circulation, Development, Finished, Ready for approval).
- Document Hierarchy:** A tree view showing document categories like 'All View', 'Operational', 'Shared Documents', etc.
- Document News:** A section currently showing 'NO CONTENT'.
- Top visited documents:** A horizontal bar chart showing the most accessed documents.
- Attention Required:** A table listing documents that need attention, with columns for Name, Revision valid to, Related to, and Status.

The 'Documents' list view includes a toolbar with the following actions: + CREATE, VISUALIZE, FILTER, EXPORT TO EXCEL, EXPORT TO PDF.

Below the toolbar is a table with the following data:

Document:	Rev.:	Short Description:	Owner:	Responsible:	Author(s):	
CompanyDrive	0	Link to CompanyDrive where the latest models files is available				EDIT
QualiWare homepage	0	Link to QualiWare's website	CEO	Head of Communication	Customer Success	EDIT
Test external doc	0	Test document in Word				EDIT

The list can be filtered, visualized and exported, and you can create new and edit existing.





Organization

Organization

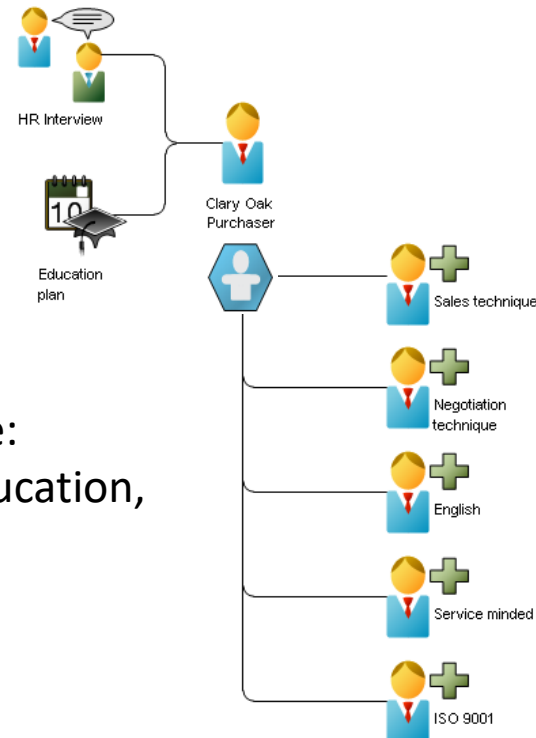
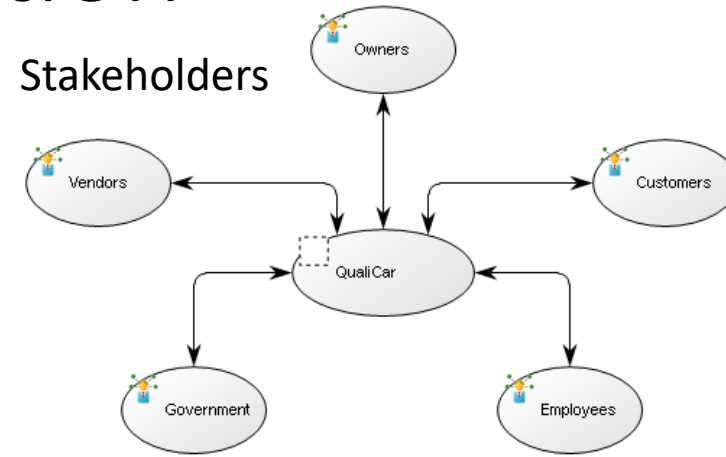

Human Resource:
competence, education,
plans

Organization units and positions

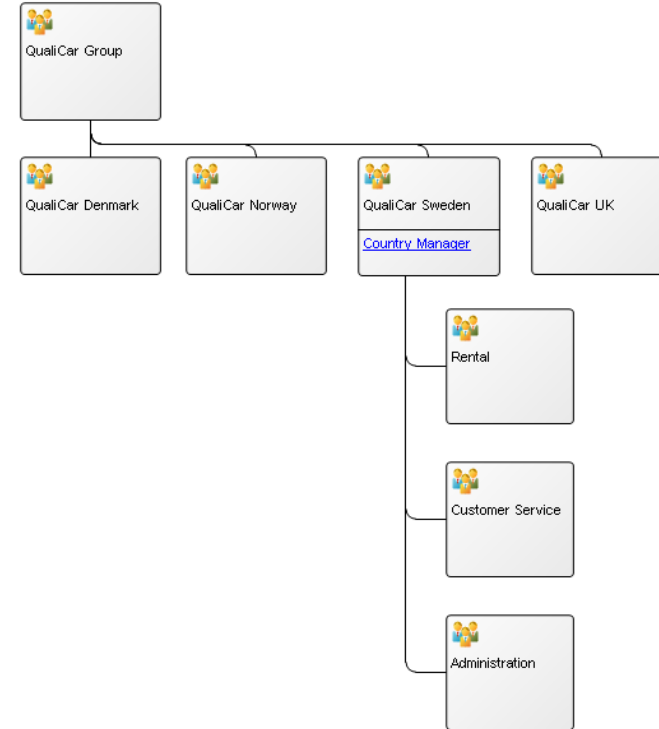

Organization

The diagram **OrganizationDiagram** is used for describing organizational structures

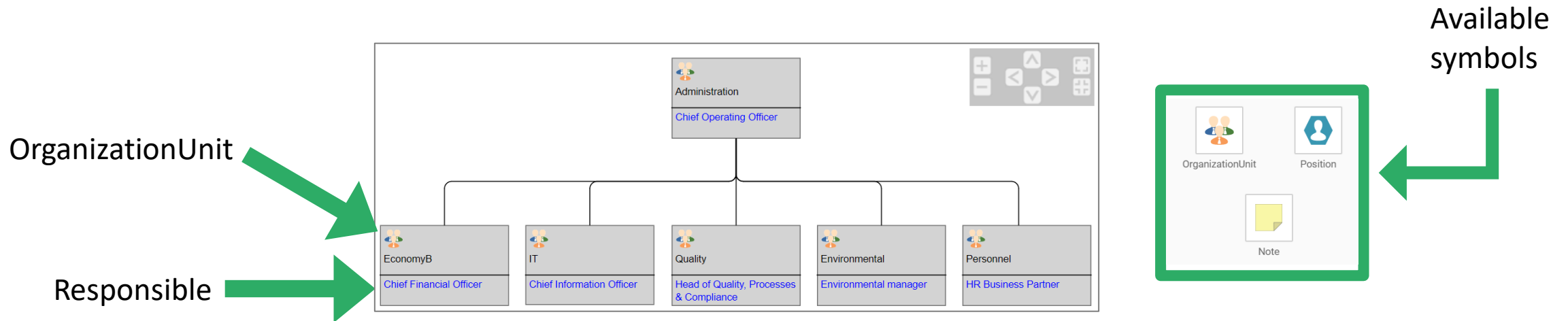

OrganizationUnit

 Procurement
Head of Procurement(*)
Manager procurement Frankfurt Manager Procurement Sao Paulo

Properties for **OrganizationUnit**

Procurement

OrganizationUnit

Address

HealthCheck

Describe



> Associate

> Governance

Short Description:

Responsible:  Head of Procurement

Resources:

Name	Template
 Manager procurement Frankfurt	Position
 Manager Procurement Sao Paulo	Position

FTE: _____

Staff

Breaks Down To:

Name	Template
No items to display	

Show on diagram: Name, Responsible, Resources

OK CANCEL APPLY

← Short description

← Responsible

← Resources

← Breaks down to

← Select what should be shown on the diagram

Position



Properties for **Position**

Compliance Manager

- Position
- Minimum req.
- Authority
- Describe
- > Associate
- > Governance
- Minimum Comp.

Short Description: **Format** **B** *I* U abc x₂ x² [List Icons]

Responsible for GDPR compliance and ISO certifications

Task: **Paragraph** **B** *I* U abc x₂ x² [List Icons]

Plan and execute internal audits
Plan and coordinate external audits with external auditors

Position holders: **+ CREATE** **EDIT** **INSERT** **REMOVE** [Dropdown]

Name	Template
Mr. Right	Person

Goals:

Name	Template
ISO certification	Goal
GDPR compliance	Goal

OK CANCEL APPLY



Short description



Task



Position holders
Link to Person(s)

Person

New Person

Person

Job Experience

Competences

Data

Specification

Address

Certificate

Authority

Name: * New Person

Short description:

Title:

Initials: Gender: ▾

Job description:

Training:

Qualifications:

OK CANCEL APPLY

Properties for a **Person**



Short description



Title
Gender
(will affect the symbol)



Relations organization - process

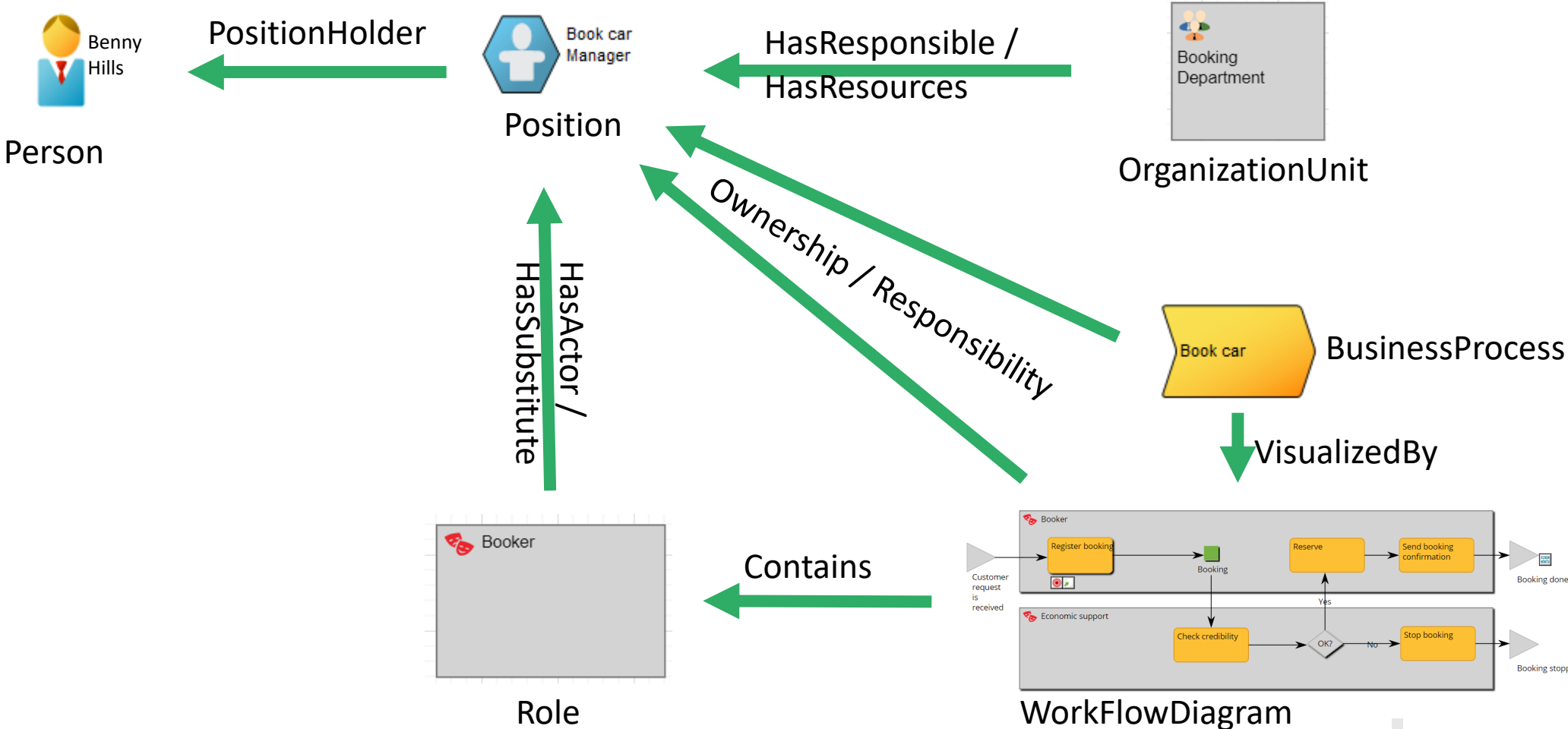

The image features two large satellite dishes in the foreground, one on the left and one on the right, both pointing towards the sky. The dishes are black with a mesh-like surface. The background is a dramatic sky at sunset or sunrise, with a bright sun partially obscured by clouds, creating a warm, golden glow. The sky transitions from a pale yellow near the horizon to a deep blue at the top. In the distance, a range of low mountains is visible under the hazy light. A semi-transparent green horizontal band runs across the middle of the image, containing the text 'Linking across diagrams' in white. In the bottom right corner, the word 'qualiware' is written in a bright green, lowercase font.

Linking across diagrams

qualiware

Linking across diagrams

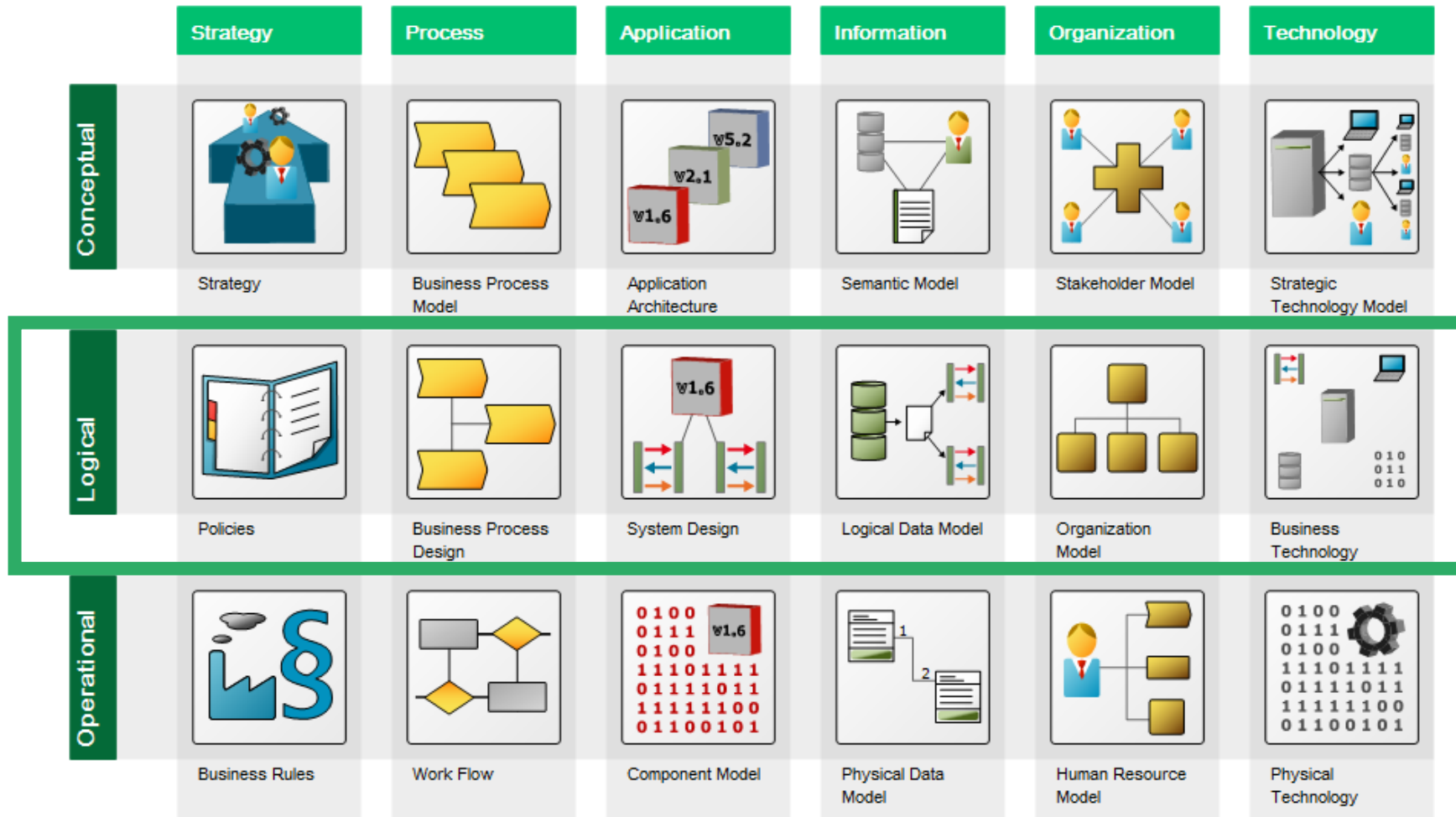

A key feature of the QualiWare tool is the re-use and linking between objects in the repository.

Relations between models

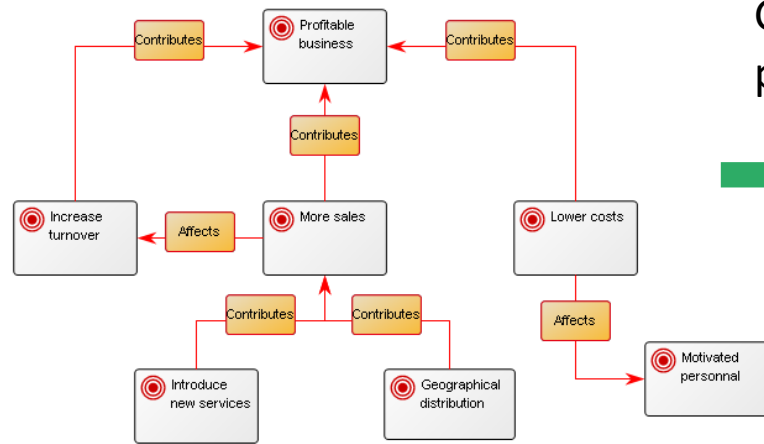

Goals govern business processes

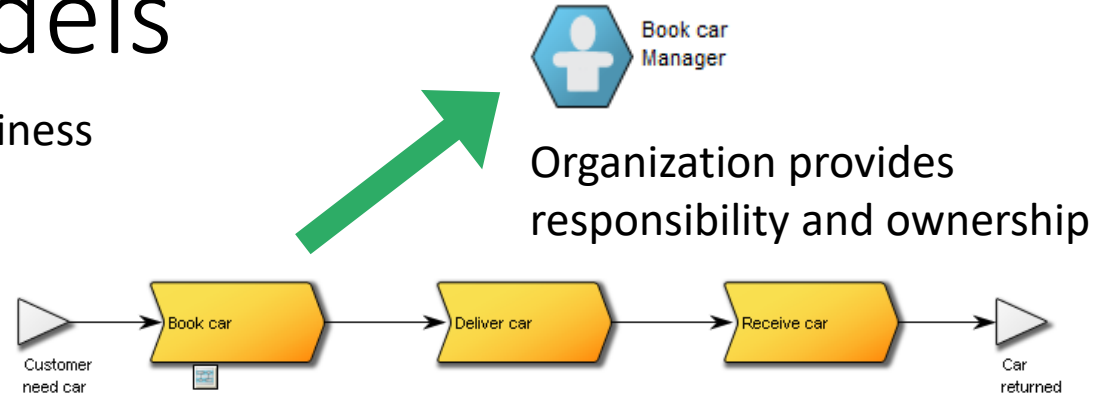

Organization provides responsibility and ownership



Processes handle information

Information is handled by applications

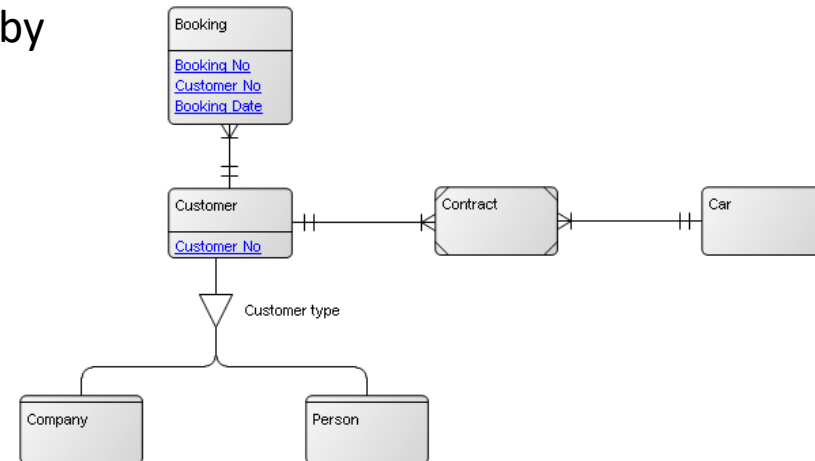
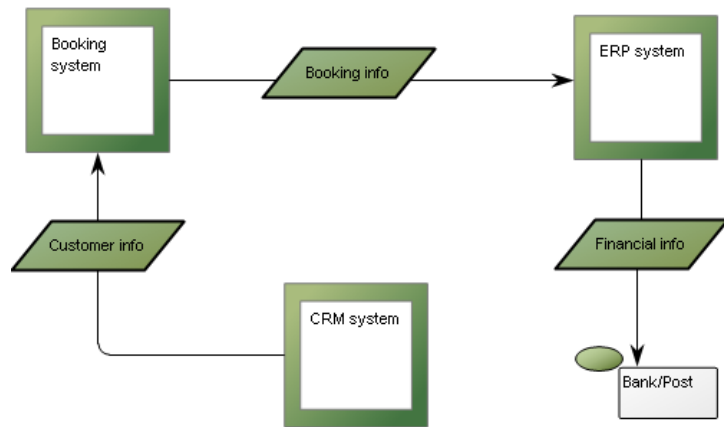

Linking to other objects using a spreadsheet

 Edit

- BusinessProcess properties**
- Process Risk for diagram
- Input, Guides, Output, Enablers

From the diagram dashboard, find spreadsheet(s) in the Edit tile, or Click the tab "Business Processes" tab in classic view.

In the spreadsheet it is easy to create relations to other objects

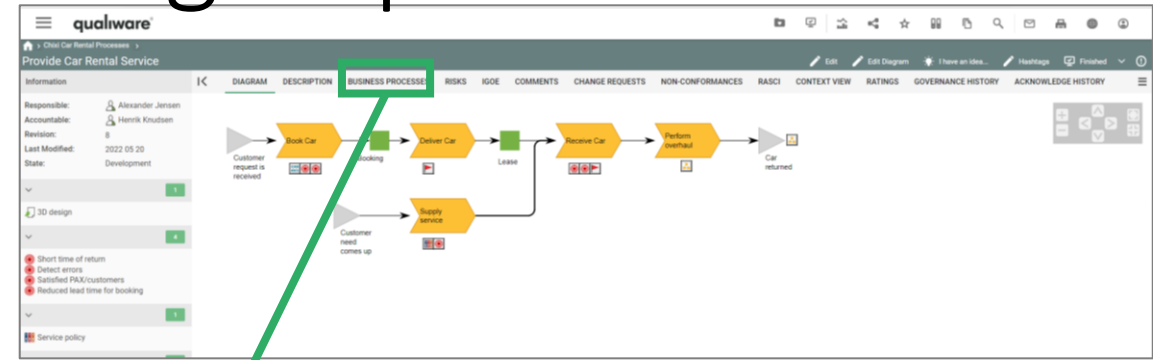

qualiware

Chixi Car Rental Processes > Provide Car Rental Service

DIAGRAM DESCRIPTION BUSINESS PROCESSES RISKS IGOE COMMENTS CHANGE REQUESTS NON-CONFORMANCES RASCI CONTEXT VIEW RATINGS GOVERNANCE HISTORY ACKNOWLEDGE HISTORY

HOME INSERT DATA SETTINGS

fx







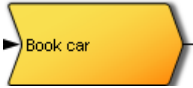

	A	B	C	D	E	F	G	H	I	J	K
1	Name:	Short Description:	Purpose:	Owner:	Responsible:	Resources:	Uses information:	IT Support:	Deliver Capability:	Compliance with:	Associated Documents:
2	Book Car	When a customer request is received, one or more vehicles are reserved for a certain period of time.	The purpose is to reserve a vehicle for a certain period of time		Estel Jons	Peder Witt Scheller Joel Bedore Fredrik Voicemail...	Booking type Car Customer...	Booking system Customer system CCTV System (Closed Circuit TV)			
3	Deliver Car	To hand over the car to the customer swiftly and with a kind recep...		Ture Dubb	Lotte Slaaby	Igor Skurup Larsen Sven Stift Vuorio, Timo...	Car Car Car...				
4	Perform overhaul			Bent Crosier	Akira Witt Scheller	Linda Bartkowiak Håkan Albertsen Carina Ali Munawar...	Car Service order Hardware Components...	Customer system Storage system			
5	Receive Car	To inspect the returned vehicle and to finish the lease with the customer.		Adam Woodworth	Frankfurt, Finance Manager and HR Coordinator	Mimmi Markell Alans Puri Anders Carr	Rental agreement Rental contract Reservation	ADP			
6	Supply service	To ensure that QualiCar fulfils the commitment stated in our Service policy		Anette Prindahl	Daniel Slaaby	Oscarsson, Fredrik Paul B. Madsen Kees M. Akselsen					

See more about Spreadsheets later in this introduction

Organizational Objects

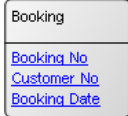
 **BusinessProcess**

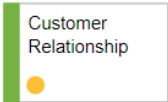
Properties of the BusinessProcess

 **Person** |  **Position** |  **Role** |  **Org Unit** |  **Information-Concept** |  **Information-System** |  **Capability** |  **Regulation** |  **External-Document**

Visualize content and relations

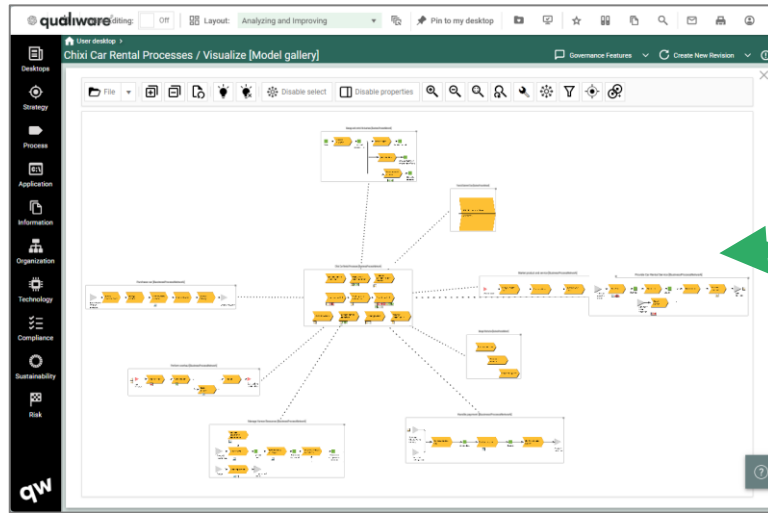

Model Gallery

-  Visualize
- ❄ Model gallery
 - ❄ Model Context 3D
 - ❄ Context View 2D
 - ❄ Process context
 - ❄ Risk and Controls
 - ❄ Process RASCI
 - ❄ Process digitalization
 - ❄ Process compliance

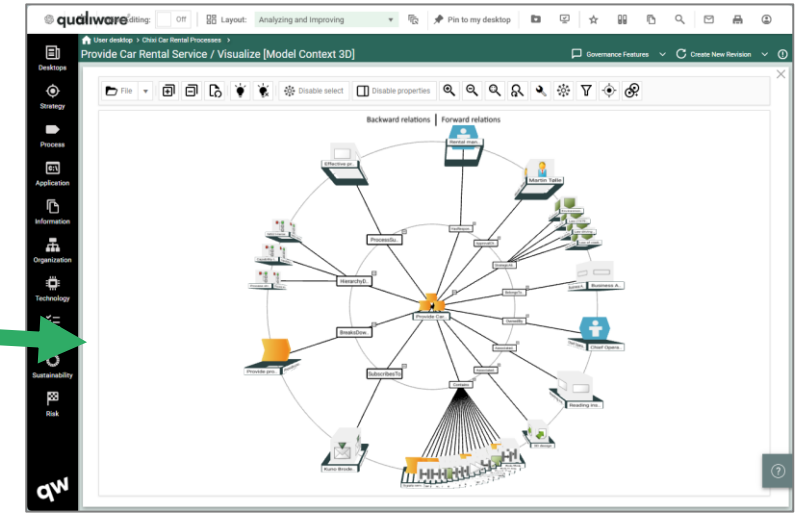

Model Context 3D

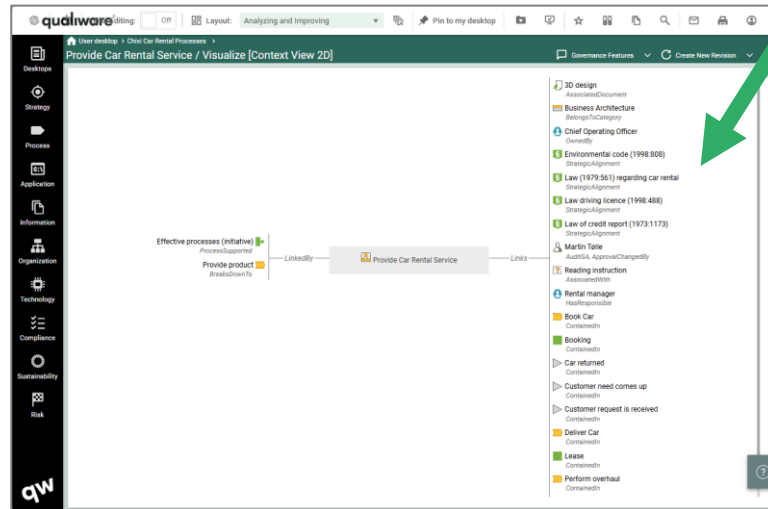

Context View 2D

You can visualize the content and their relationships using the many visualization available from the dashboards.

Read more about [Visualizations on our Center of Excellence](#)

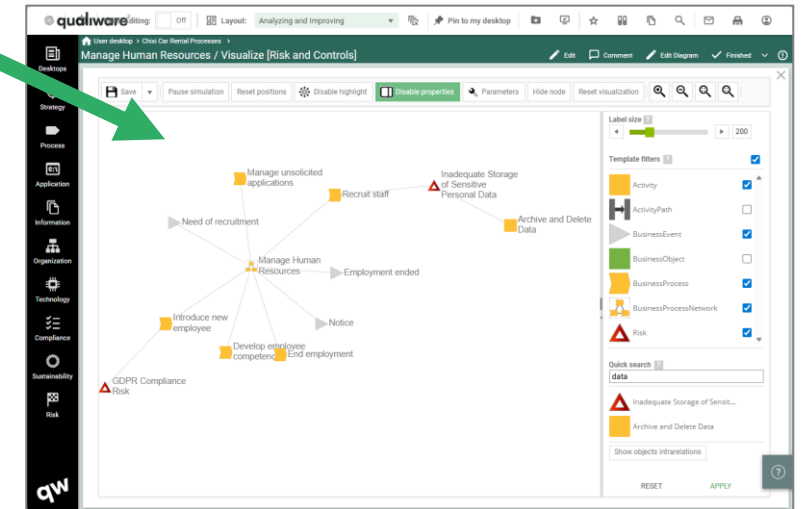

Dynamic visualizations



Spreadsheet

qualiware

General intro to spreadsheet

The spreadsheet functionality in QualiWare enables you easy to explore and edit the properties and the relationships for objects in the repository.

Spreadsheets can be found in the menu, on desktops and on the diagrams workspaces.

In general menu and desktop lists cover the 'whole' repository content and a diagram spreadsheet focuses on the content contained in the diagram, e.g. BusinessProcesses and their properties.

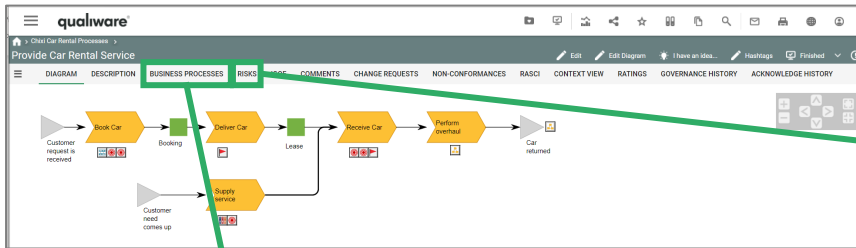
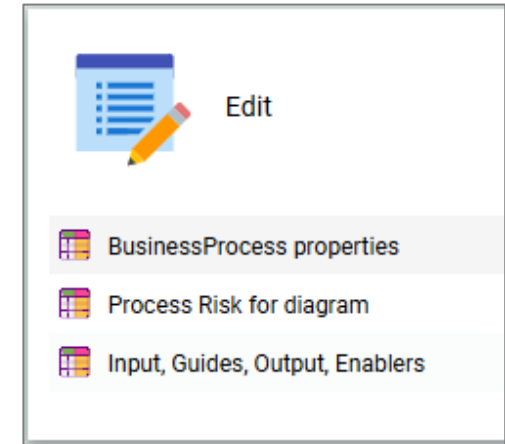

Process/Activity	Risk	Likelihood	Significance	Control/Prevention Impact	Legal/Regulatory Impact	Operational Impact	Control	Responsible	Risk/Impact	Residual	Residual
Manage and control business	Highly likely	High	High	High	High	High	High	High	High	High	High
Manage and control business	Highly likely	High	High	High	High	High	High	High	High	High	High
Manage and control business	Highly likely	High	High	High	High	High	High	High	High	High	High
Manage and control business	Highly likely	High	High	High	High	High	High	High	High	High	High
Manage and control business	Highly likely	High	High	High	High	High	High	High	High	High	High

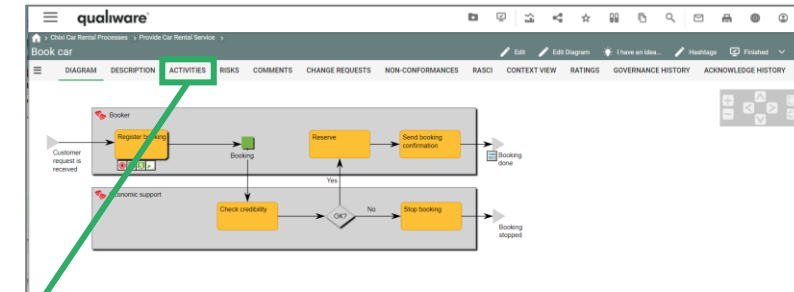

	Name:	Short Description:	Purpose:	Owner:	Responsible:	Resources:	Uses information:	IT Support:	Deliver Capability:
1	Book Car	When a customer request is received, one or more vehicles are reserved for a certain period of time.	The purpose is to reserve a vehicle for a certain period of time	Håkan Wilde	Christel Jons	Peder Witt Scheller Joel Bedore Fredrik Voicemail...	Booking type Car Customer...	Booking system Customer system CCTV System (Closed Circuit TV)	
2	Deliver Car	To hand over the car to the customer swiftly and with a kind recep...		Ture Dubb	Lotte Slaaby	Igor Skurup Larsen Sven Skift Vuorio, Timo...	Car Car Car...		
3	Perform overhaul			Bent Crosier	Akira Witt Scheller	Linda Bartkowiak Håkan Albertsen Canna Ali Munawar...	Car Service order Hardware Components...	Customer system Storage system	
4	Receive Car	To inspect the returned vehicle and to finish the car to the customer swiftly and with a kind recep...	This purpose text has been changed	Adam Woodworth	Frankfurt, Finance Manager and HR Coordinator	imi Markell Geir's Fun lers Carr	Rental agreement Rental contract Reservation	ADP	
5	Supply service	To ensure that QualiCar fulfils the commitment stated in our Service policy		Anette Prindahl	Daniel Slaaby	Oscarsson, Fredrik Paul B. Madsen Kees M. Akseisen			

	Name:	Short Description:	Owner:	Responsible:	Resources:	Uses information:	IT Support:	Compliance with:	Assoc
1	Stop booking		Kristian K. Wilumsen	Hans-Juergen Jensen	Laurent Nilsson Andreas Fredrik Hans Hansen...				
2	Check credibility		Andrew Per	Ji-Hee pluzanski	Anders Granat Lucas Tæstesen				
3	Send booking confirmation		Jens Anker Hansen	Grzegorz Jarleskog	Bert Emilsson Reiner Qiang Carl Narumet...				
4	Reserve		Martin Jitsunari	Jacob D Lund					
5	Register booking	The booking is registered together with customer data.	Gary Keyes	Usman Ali Munawar	Carl Soto Lennart Congress Joachim Smith Larsen...				

Linking to other objects using a spreadsheet

The spreadsheet enables easy update of properties and relationships between objects

1 Text-fields can be edited directly in the cell.

2 Other fields link to other objects. These can be updated by clicking on the link symbol.

Objects with green background are locked/approved.

The screenshot shows the QualiWare interface with a spreadsheet for editing business process properties. The spreadsheet has the following data:

	A	B	C	D	E	F	G	H	I
1	Name:	Short Description:	Purpose:	Owner:	Responsible:				
2	Book Car	When a customer request is received, one ore more vehicles are reserved for a certain period of time.	The purpose is to reserve a vehicle for a certain period of time	Chief Operating Officer	Manager				
3	Deliver Car	To hand over the car to the customer swiftly and with a kind reception and also instructing him / her about the car's characteristics and inform about our Quality policy and Environmental policy.		Ture Dubb	Lotte Slaaby				
4	Perform overhaul								
5	Receive Car	To inspect the returned vehicle and to finish the lease with the customer.	<i>This is a new purpose description</i>	Frankfurt, Finance Manager and HR Coordinator	Adam Woodworth				
6	Supply service	To ensure that QualiCar fulfils the commitment stated in our Service policy		Anette Prindahl	Daniel Slaaby				
7									
8									

The 'Select' dialog is open over the 'Responsible' cell in row 2, showing a list of roles:

- Chief Architect
- Chief Executive Officer
- Chief Financial Officer
- Chief Force Operator
- Chief Information Officer
- Chief Operating Officer

A green arrow points from the 'Responsible' cell to the 'Select' dialog. A green box highlights the 'Purpose' cell in row 5, with a note 'This is a new purpose description'.

Describe the process using a spreadsheet

Properties of each of the Processes on a diagram can easily be described/modified using the Spreadsheet view.

Click the tab “**Business Processes**” to switch to the spreadsheet. (This spreadsheet lists the 5 BusinessProcesses in the Diagram and their properties)

It is possible to edit the objects directly from the spreadsheet in each of the property columns.

Any changes made will be highlighted in ***bold + italic*** and will only be applied to the objects once the “**Save**” button is clicked.

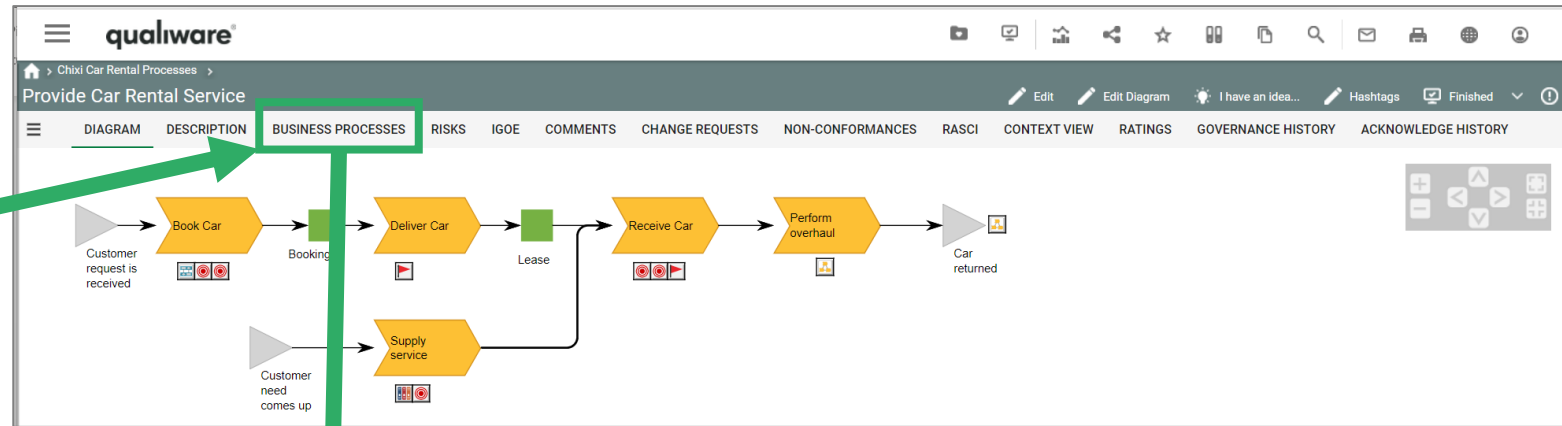



	A	B	C	D	E	F	G	H	I
	Name:	Short Description:	Purpose:	Owner:	Responsible:	Resources:	Uses information:	IT Support:	Deliver Capability:
1									
2	Book Car	When a customer request is received, one or more vehicles are reserved for a certain period of time.	The purpose is to reserve a vehicle for a certain period of time	Håkan Wilde	Christel Jøns	Peder Witt Scheller Car Fredrik Voicemail...	Booking type Customer...	Booking system Customer system CCTV System (Closed Circuit TV)	
3	Deliver Car	To hand over the car to the customer swiftly and with a kind receipt...		Ture Dubb	Lotte Slaaby	Igor Skurup Larsen Sven Stift Vuorio, Timo...	Car Car Car...		
4	Perform overhaul			Bent Crosier	Akira Witt Scheller	Linda Barkkowiak Håkan Albertsen Carina Ali Munawar...	Car Service order Hardware Components...	Customer system Storage system	
5	Receive Car	To inspect the returned vehicle and to finish the lease with the customer.	<i>This purpose text has been changed</i>	Adam Woodworth	<i>Frankfurt, Finance Manager and HR Coordinator</i>	imi Markell his Puri lers Carr	Rental agreement Rental contract Reservation	ADP	
6	Supply service	To ensure that QualiCar fulfills the commitment stated in our Service policy		Anette Prindahl	Daniel Slaaby	Oscarsson, Fredrik Paul B. Madsen Kees M. Akselsen			

Objects with green background are locked/approved.

Easy access to Spreadsheets from the dashboards

 Edit

-  BusinessProcess properties
-  Process Risk for diagram
-  Input, Guides, Output, Enablers

Chixi Car Rental Processes / Edit [BusinessProcess properties]

	A	B	C	D	E	F	G	H	I	J	K
1	Name:	Short Description:	Purpose:	Owner:	Responsible:	Resources:	Uses Information:	IT Support:	Deliver Capability:	Compliance with:	Associated Documents:
2	Handle payment	Handle all payments from clients	Getting paid for services	Carina Kjaer Sorensen	Michael Kjaer Sorensen	Andro Christensen Infracore Mills	Payment Customer	Economy system			Leasing Contract Europe
3	Manage and control business	Management and control of the business on an overall level.	To control and secure an effective and profitable business.	Michael Zhang	Magnus Vejsg Pedersen	Kurt Ross		Economy system Customer system			This is manag...
4	Manage human resources			Agostino Holm	Kirsten Mogensen	Victor Egebo Fredrik Laage Olsen Margo Blim Finkelstein					
5	Manage Infrastructure	Management of physical operational infrastructure!		Marianne Florida	Frank Petersson	Michael Slaaby				ISO 9001:2008	
6	Market product and service			Lars Brown	Chu Nederschieer	Arun Kesppi Vladimir Kovalenko Thomas Lidholm	Car Customer				
7	Perform overhaul					Linda Barikowak Håkan Albertsen	Car Service order	Customer system Storage system			

Chixi Car Rental Processes / Edit [Process Risk for diagram]

	A	B	C	D	E	F	G	H	I	J	K	L	M	N
1	Process/Activity:	Risk:	Likelihood:	Significance:	Corporate Finance Impact:	Corporate Reputation Impact:	Legal Compliance Impact:	Project Finance Impact:	Control:	Responsible:	Residual likelihood:	Residual significance:		
2	Handle payment	7.6 Invoices for fictitious vendors are entered into the system for payment.	Low	Substantial					7.6.2 Vendor approval process exists preventing entry of fictitious vendors into the system.	Elvira Gravaard	Remote	Negligible		
3	Manage and control business	7.19 Purchases are not recorded in the proper period.	Low	Moderate										
4	Manage human resources													
5	Manage Infrastructure													
6	Market product and service	1.2 Supply costs are not optimized because the Company does not	Remote	Catastrophic	5.2 > € 100 mill				The purchase order is confirmed with supplier	Jens Anker Hansen	Remote	Moderate		

Chixi Car Rental Processes / Edit [Input, Guides, Output, Enablers]

	A	B	C	D	E	F	G	H	I	J	K	L
1	Name:	Start event:	Input:	Guides:	Output:	Enablers:	End event:	Name:	Output:	Name:	Name:	Output:
2	Provide product		embly									
3	Manage and control business											
4	Perform overhaul											
5	Handle payment				Customer							
6	Purchase product											
7	Manage Infrastructure											
8	Manage human resources											
9	Market product and service											

Read more about [Spreadsheets on our Center of Excellence](#)

A scenic landscape at sunset. A paved road curves through a hilly area. A person in a green shirt is running on the road. The sky is filled with colorful clouds, and the sun is low on the horizon. A green semi-transparent overlay covers the middle part of the image, containing the text 'Repository Explorer'.

Repository Explorer

qualiware

Intro to Repository Explorer



The Repository Explorer can be accessed via the action buttons in the top right corner. From the Explorer it is possible to browse the repository and get easy access to objects including creating new objects.

The screenshot shows the Repository Explorer interface with four numbered callouts:

- 1**: Points to the search bar in the top left of the repository view.
- 2**: Points to the 'BusinessProcessNetwork' template in the left sidebar.
- 3**: Points to the search bar in the top right of the repository view.
- 4**: Points to the 'Chixi Car Rental Processes' object in the main list.

Name	Template	Last modified	Status	Tags
Chixi Car Rental Processes	BusinessProcessNetwork	06/04/2022	Circulation	Chixi, Copenhagen, Car, Breakfast
Handle Car go	BusinessProcessNetwork	25/05/2018	Development	
Provide Car Rental Service	BusinessProcessNetwork	20/05/2022	Development	Rental Car
Purchase Car	BusinessProcessNetwork	25/05/2018	Development	

The preview window on the right shows a process diagram with the following steps:

- Manage and control business
- Purchase product
- Market product and service
- Provide product
- Perform overhaul
- Manage human resources
- Handle payment
- Manage infrastructure

We have split our processes in to management , main and supporting processes.

- The main processes are interrelated and directly delivers a value to our customers.
- The supporting processes enables the operation of the main processes.
- The management processes controls the main processes to satisfy the business overall goal

Revision: 48
Last modified by Alexander Jensen on 2022 04 06

- 1 Search templates types
- 2 Click template to get list of objects
- 3 Search the object list
- 4 Click object to get preview in preview window

Creating a new diagram from Repository Explorer

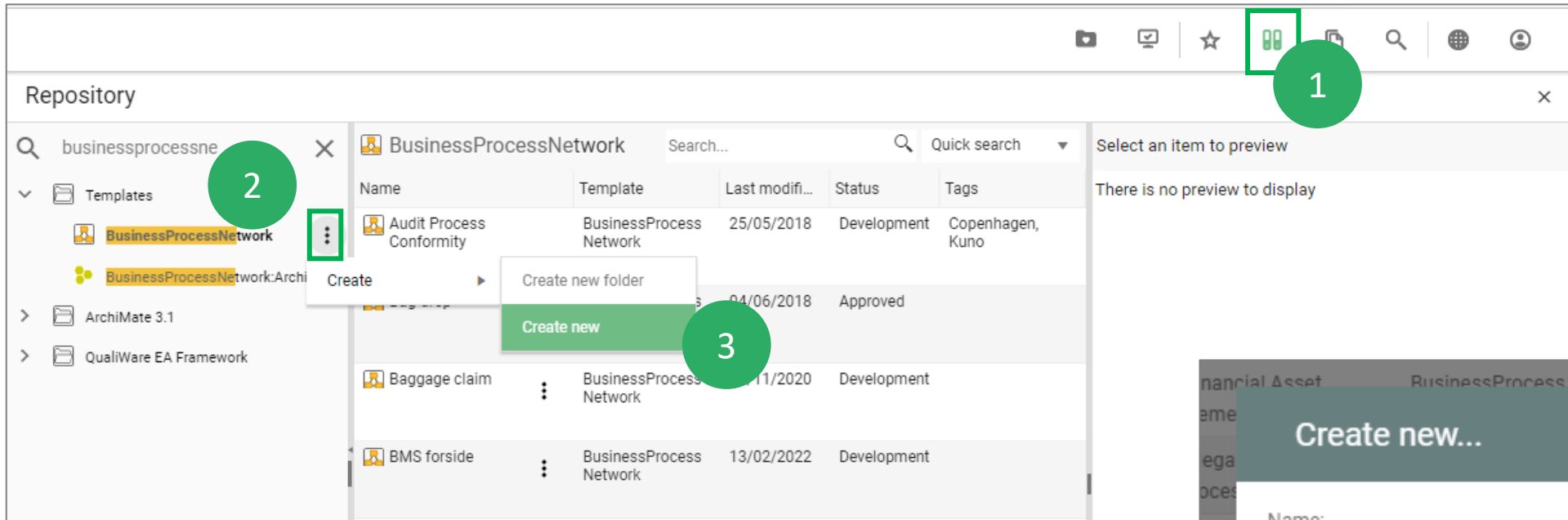

- 1 Access the Repository Explorer via the Access Button
- 2 Click the template folder and select template or search for the right template
- 3 Click the three-dot-sushi menu and fold out to select 'Create new'
- 4 Enter the name for your diagram and select 'Create'

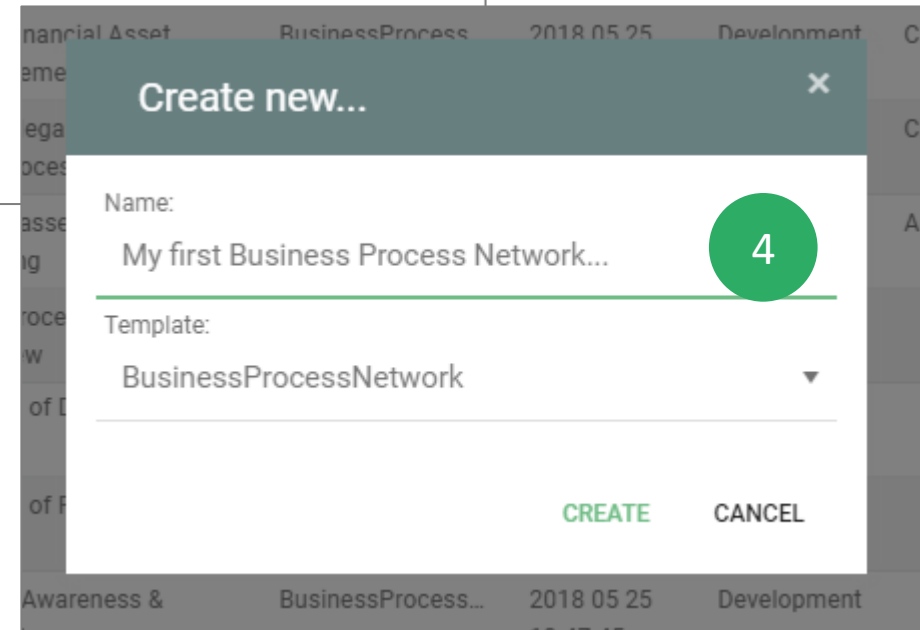

Read more about [the repository explorer on our Center of Excellence](#)